

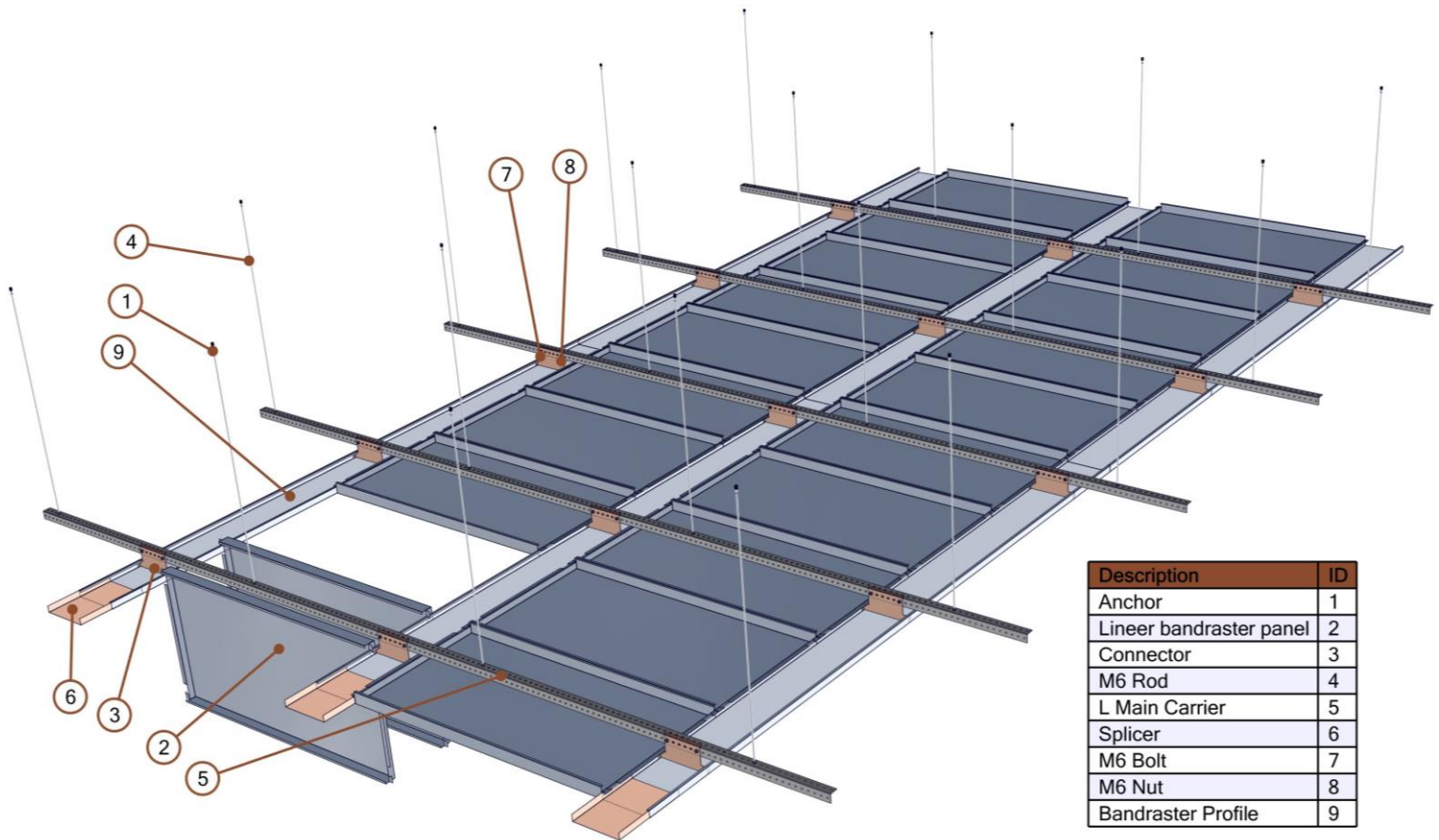

**BANDRASTER
SYSTEM**

BANDRASTER SYSTEM



- Bandraster system is suitable for wide areas as its carrier profiles run along one direction with continuation architectural look.

-

DETAIL VIEW

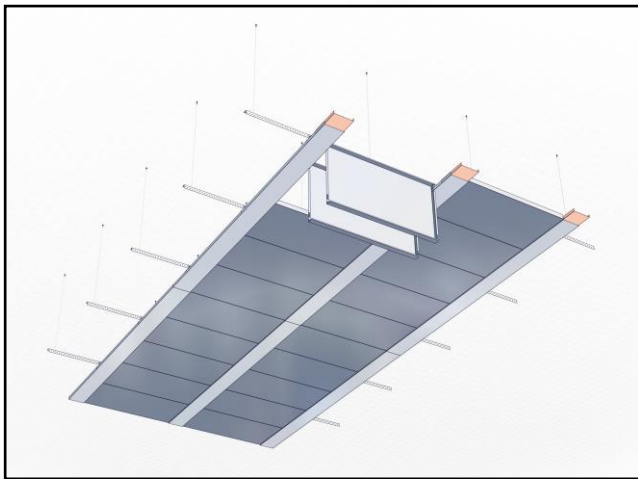
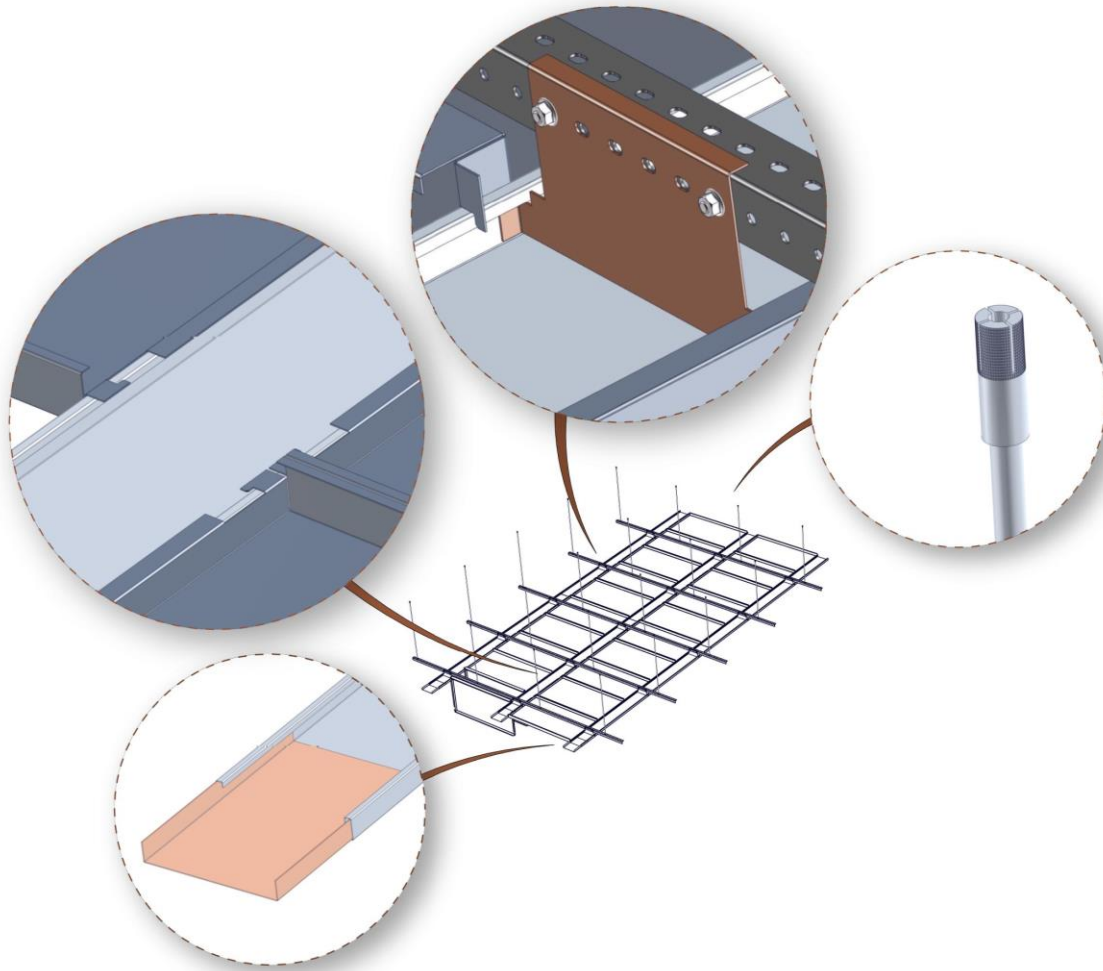

HYGIENE

High performance in Blocking bacterial formation on panel surfaces by applying anti-microbial paint.

PAINT

Prior to paint. Sensitive surface cleaning and phosphate coverage is applied. 60 minimum micron powder paint is sprayed by electrostatic system through 6 robots and cooked in a 180 meters long oven. The entire painting process takes place automatically by computer control.

MATERIAL OPTIONS

Galvanized Steel/Aluminum / Stainless Steel

ACOUSTIC

High acoustic performance with acoustic fleece up to α_w : 1,00

HUMIDITY

Galvanize panel: 90% RH

Aluminum panel: 100 % RH

LIGHT REFLECTION

Straight Panel: 9010 Painted % 86

Perforated Panel : 9010 Painted % 72

ELEMENT SPECIFICATION

1. Anchor

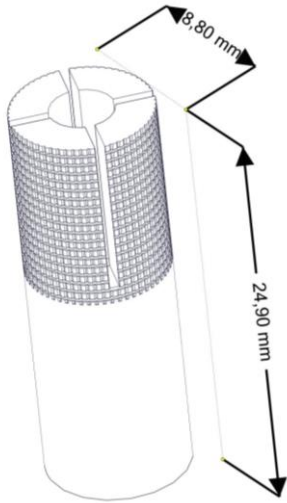

T : Ø 6 mm Galvanized Steel
H : 25 mm

3. Connector

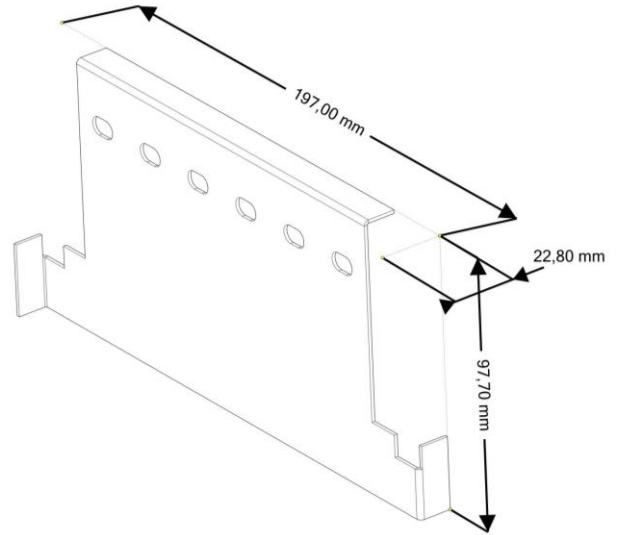



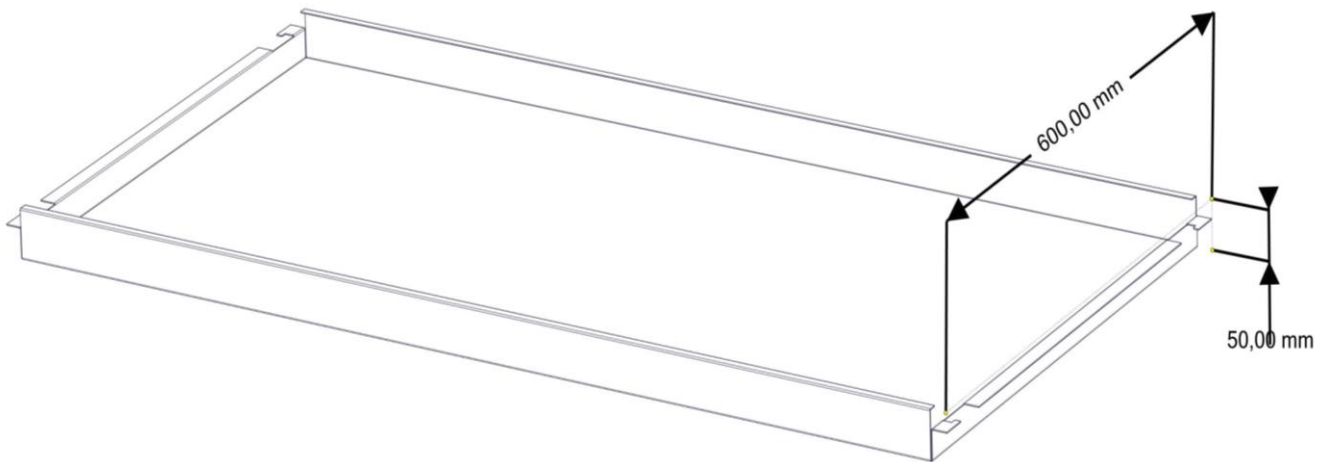

T : 1,20 mm Galvanized Steel
W : 22,80 mm H : 97,70 mm L : 197 mm

2. Bandraster Panel

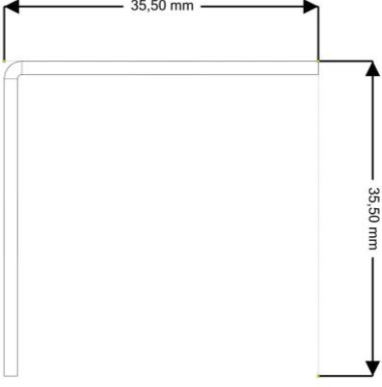
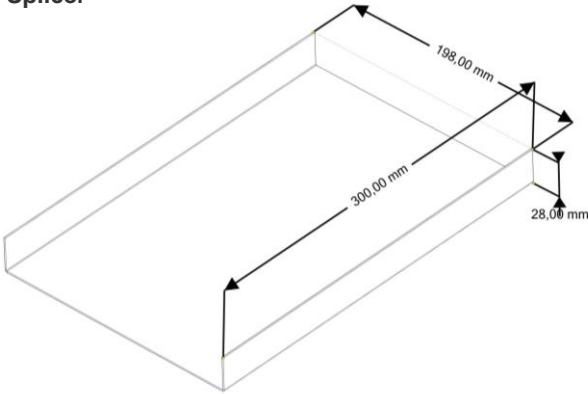

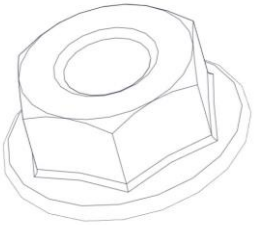
T : 1 mm Galvanized Steel
W : 600 mm H : 50 mm L : 600 mm

<p>4. M6 Rod</p> 	<p>5. L Main Carrier</p> 
<p>T : Ø 6 mm Galvanized Steel (M6 Rod) L : Max 2000 mm</p>	<p>T : 1,5 mm Galvanized Steel W : 35,5 mm H : 35,5 mm L : up to 3000 mm</p>
<p>6. Splicer</p> 	<p>7. M6 Bolt</p> 
<p>T : 1,20 mm Galvanized Steel W : -1 mm H : -1 mm L : 300 mm</p>	<p>Type : M6 Bolt Steel</p>
<p>8. M6 Nut</p> 	<p>9. Bandraster Profile</p> 
<p>Type : M6 Nut Steel</p>	<p>T : 1 mm Galvanized Steel W : 200 mm H : 30 mm L : up to 3000 mm</p>

DETAIL SECTION

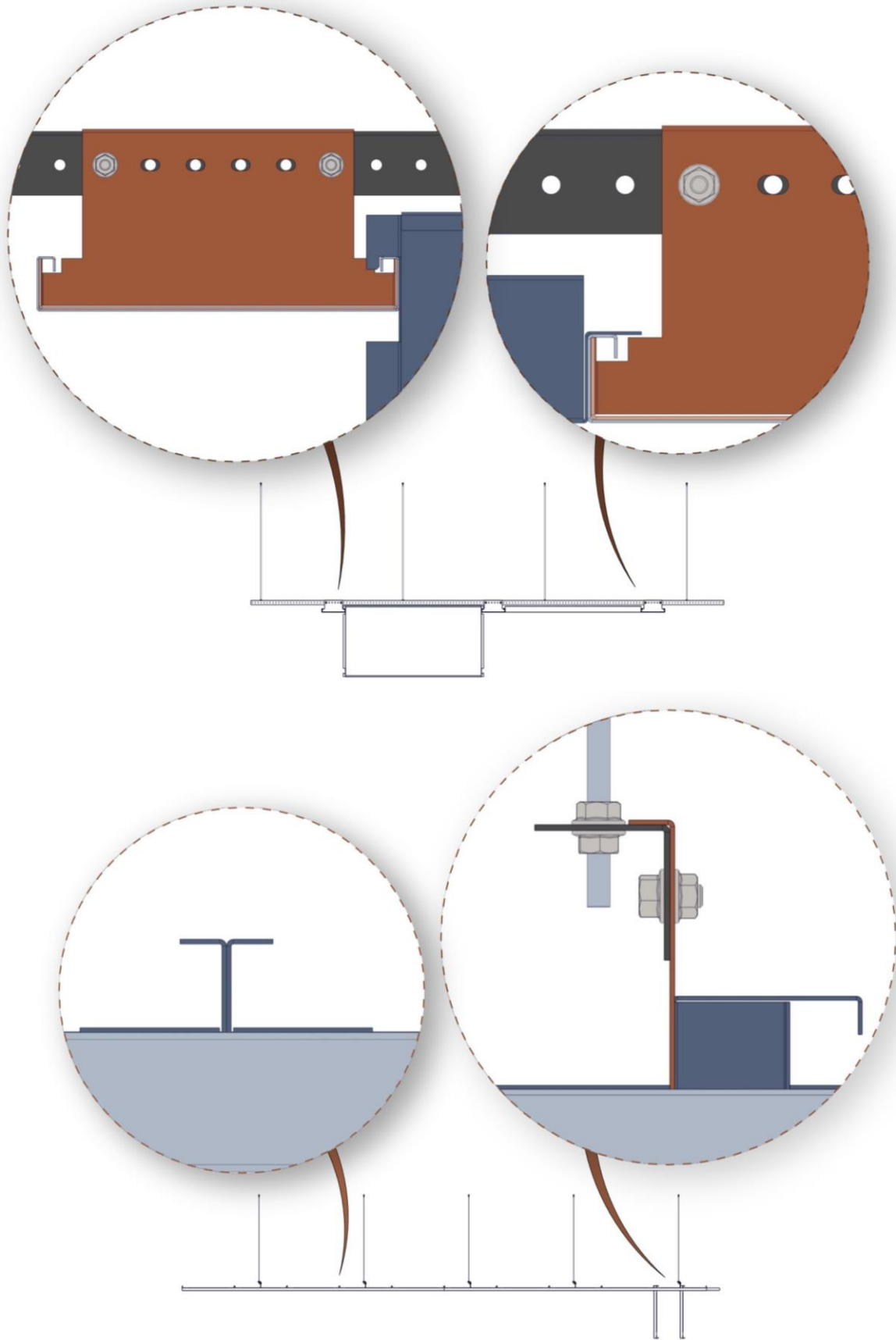

ASSEMBLY TECHNIQUE

STEP 1.

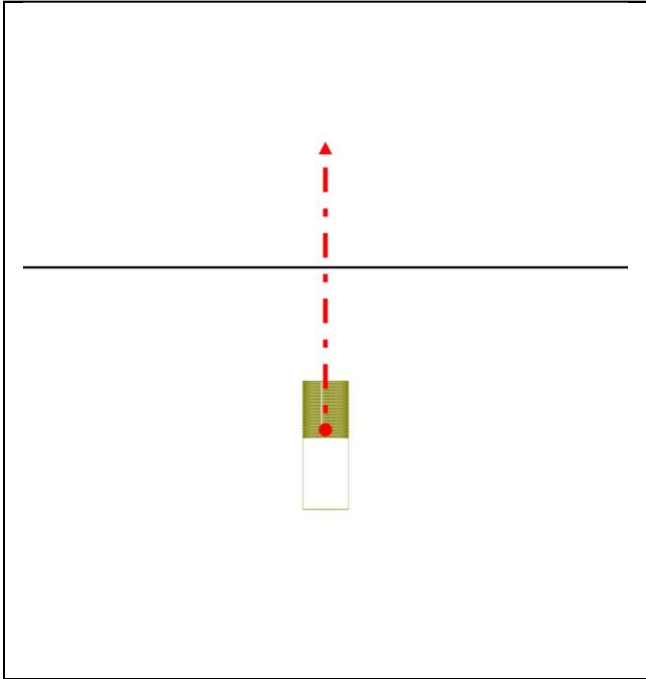

STEP 2.

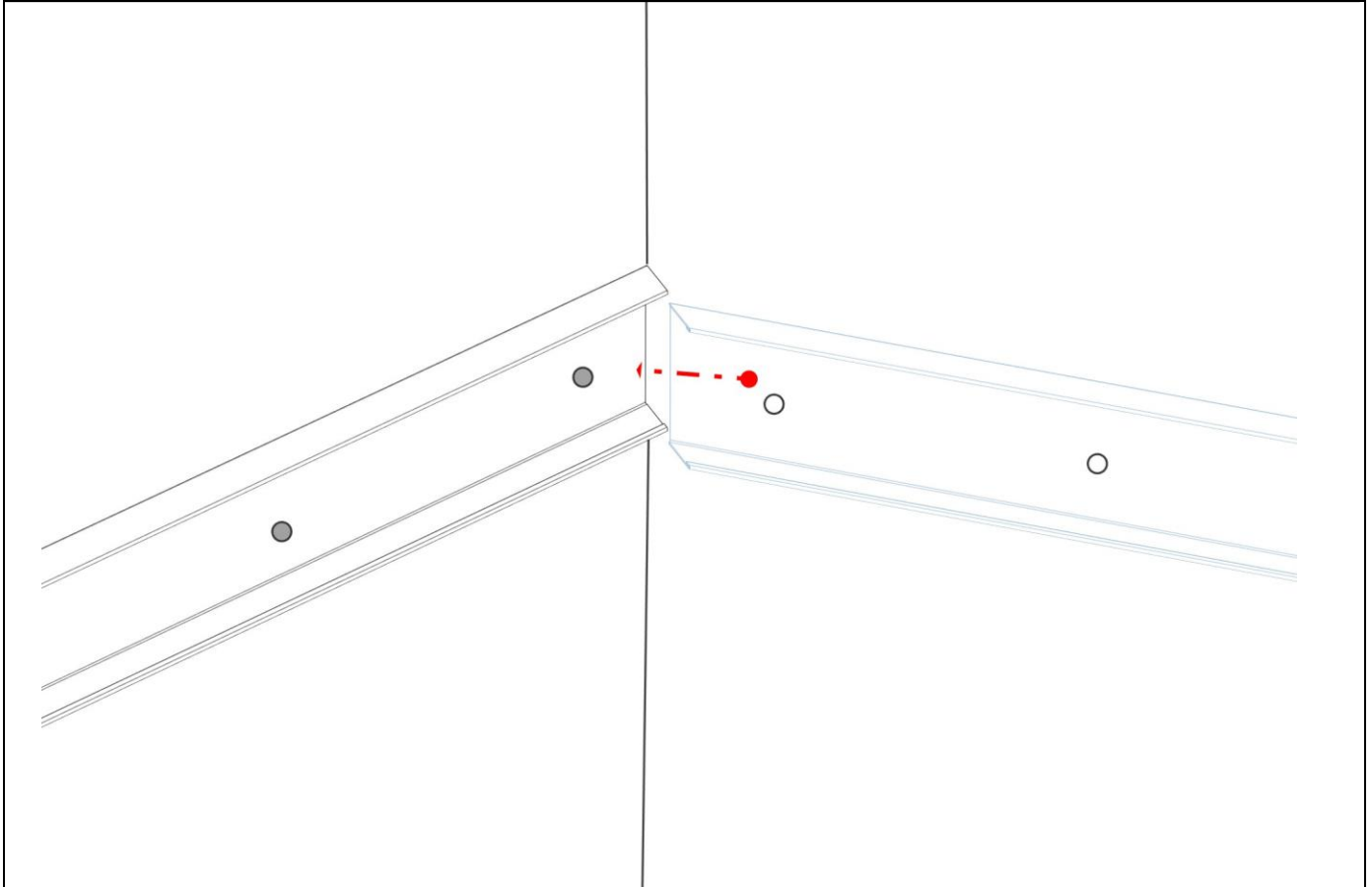
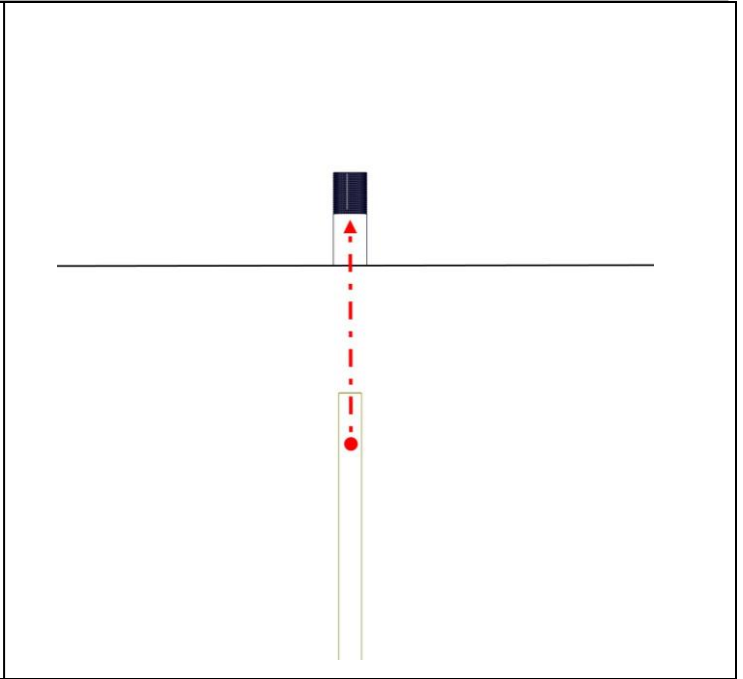

STEP 3.

STEP 4.

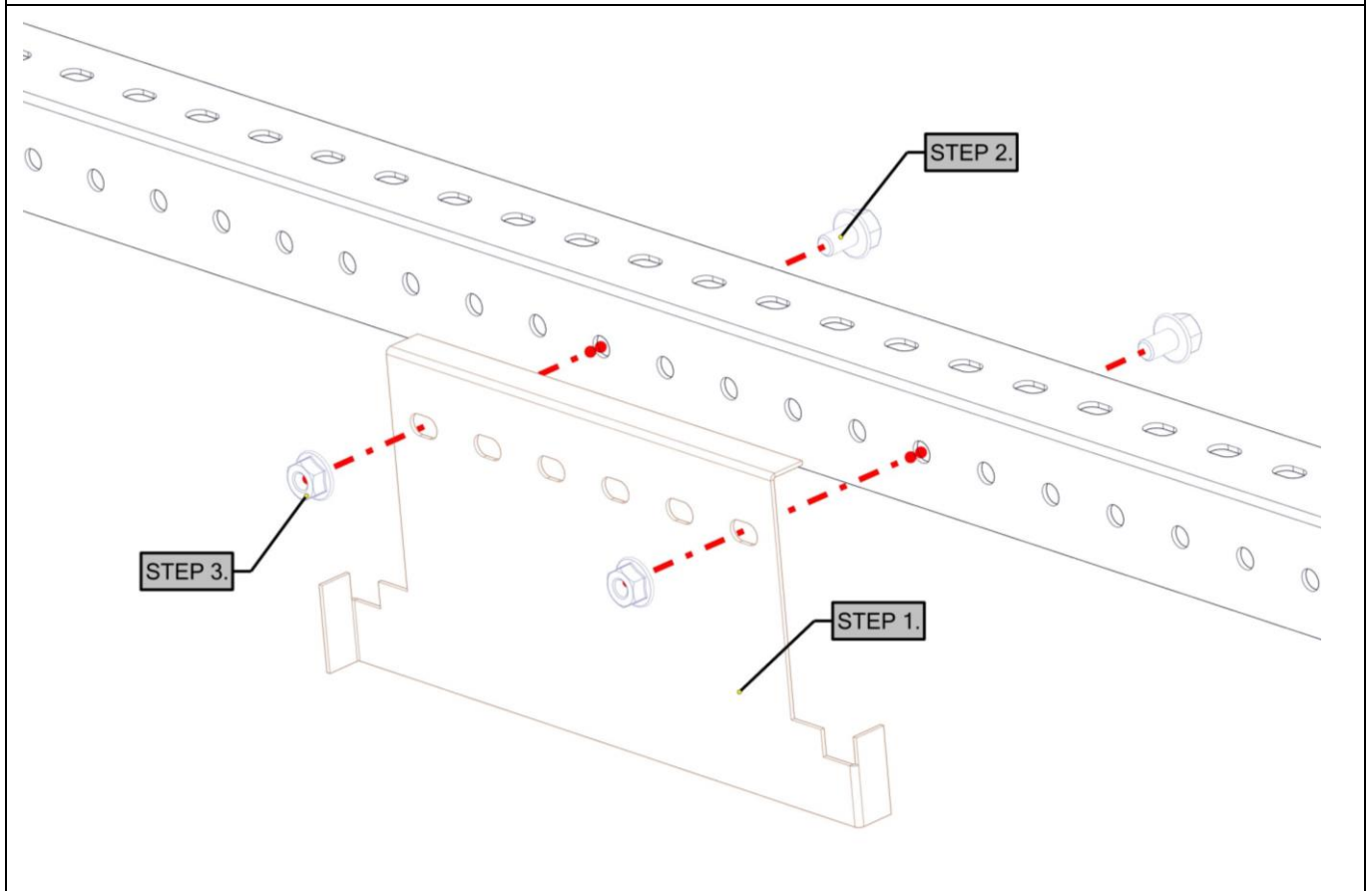
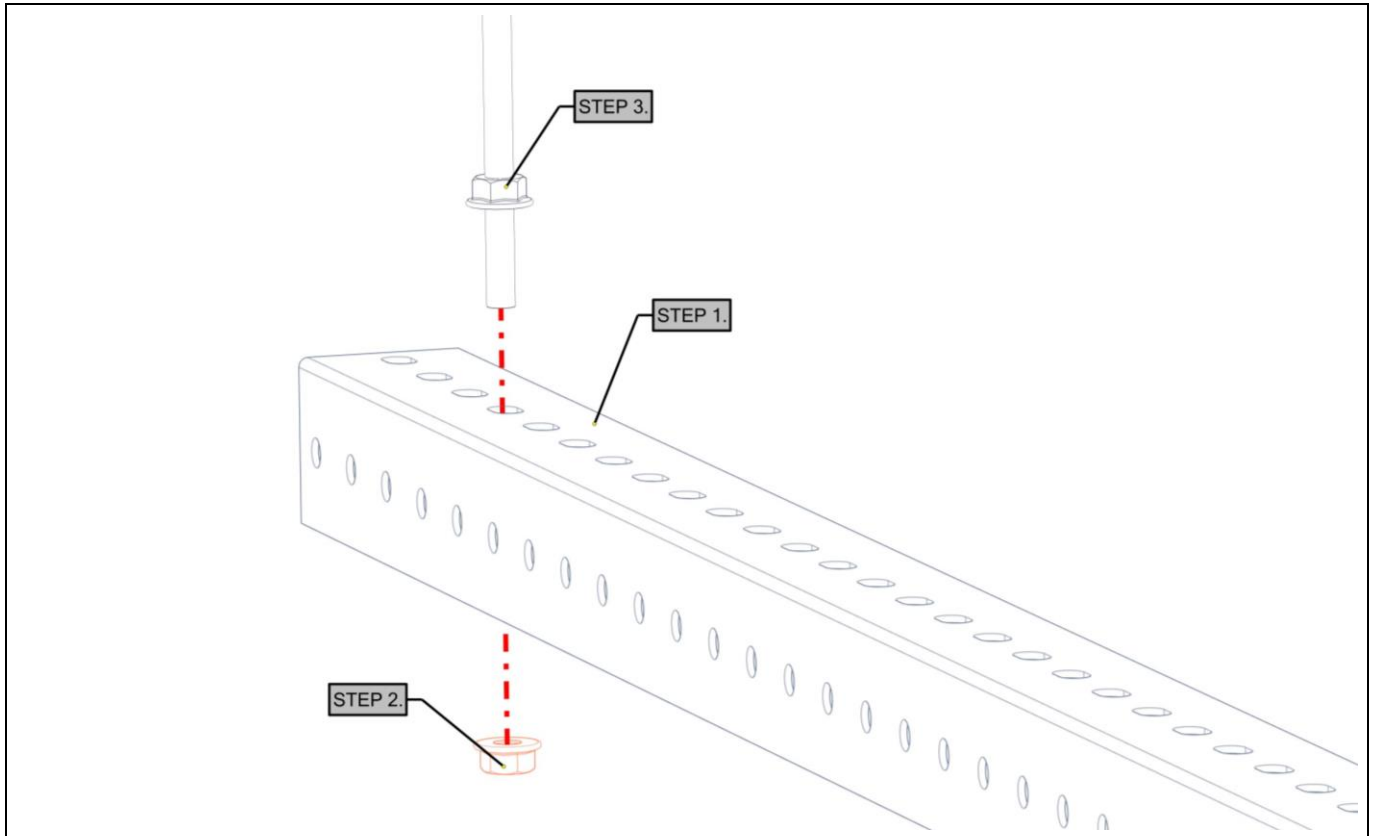

STEP 5.

STEP 6.

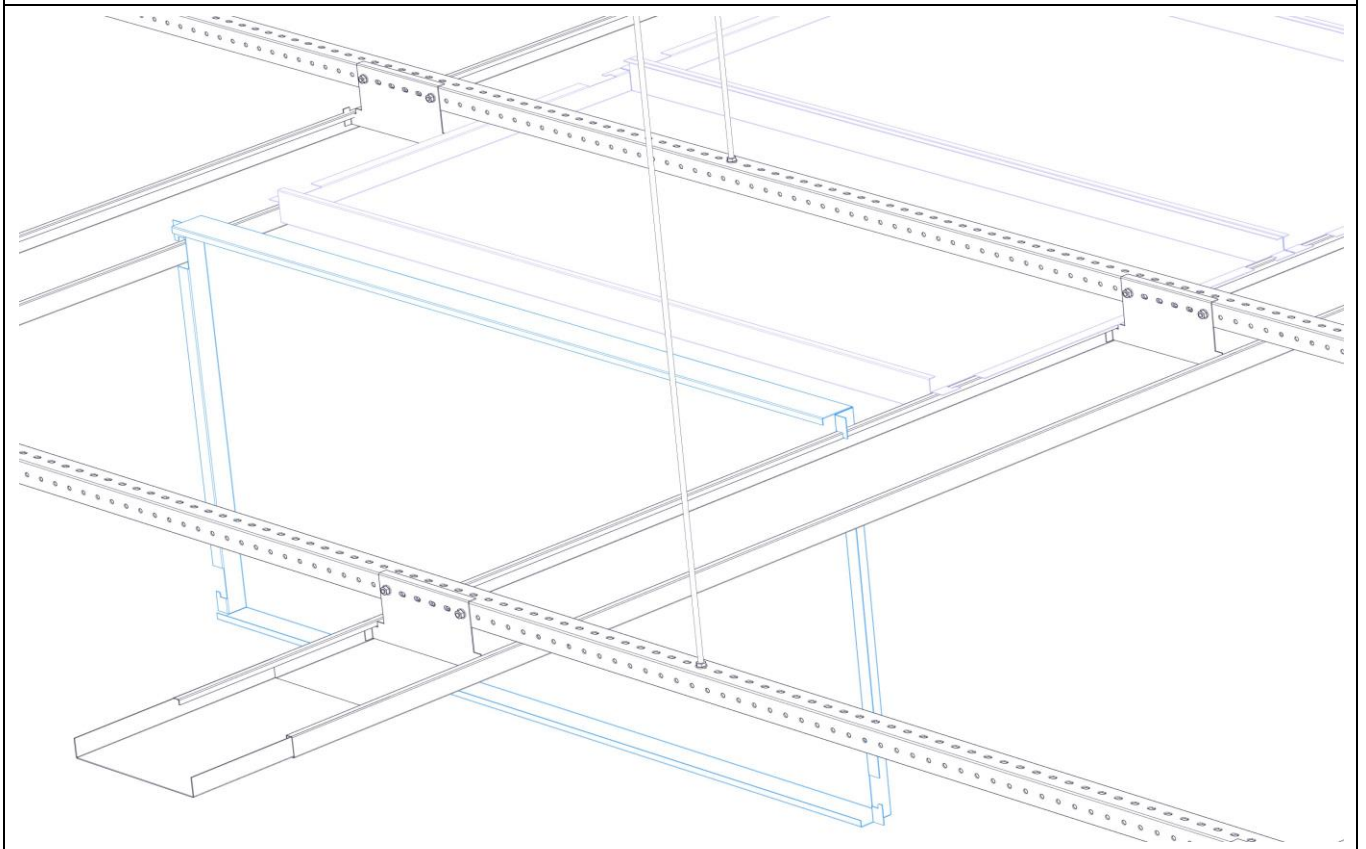
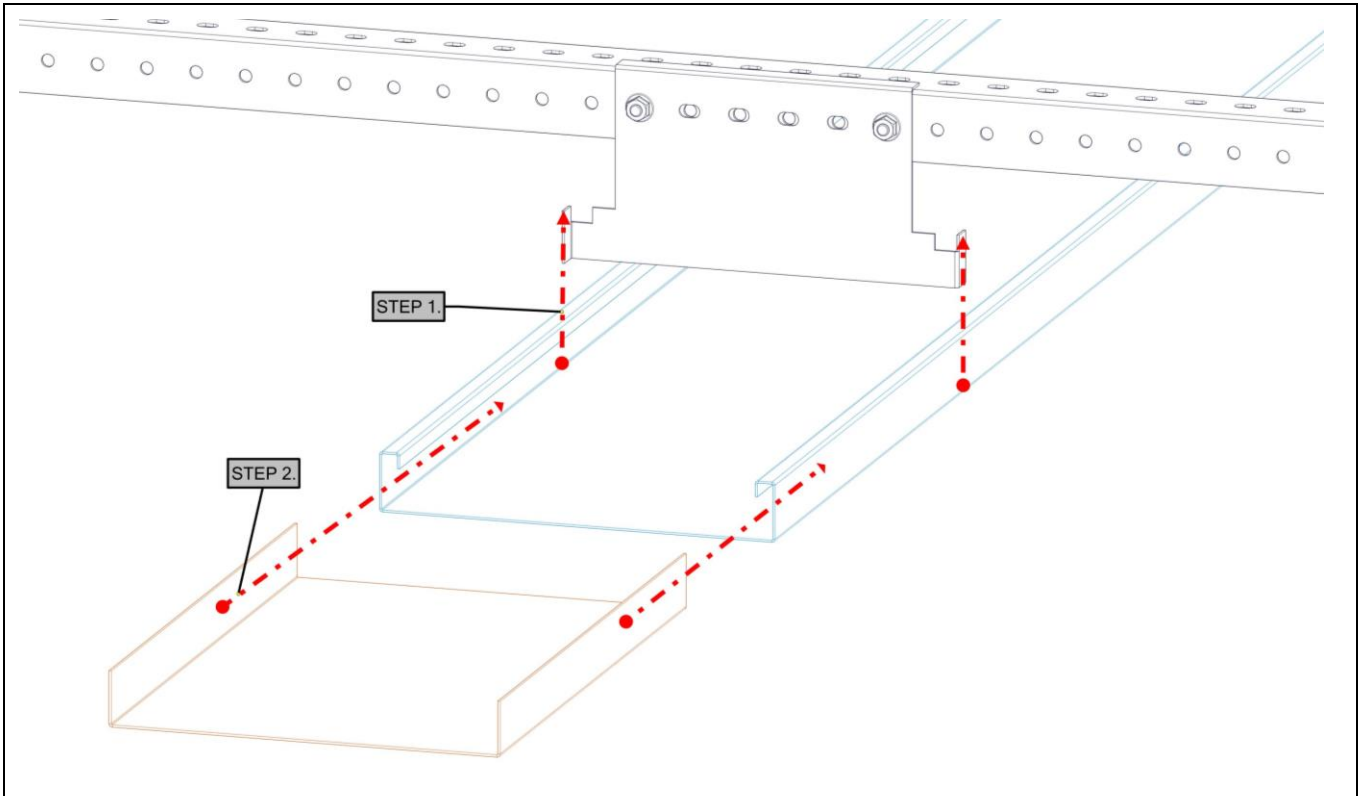

STEP 7.

Declaration of Performance

No:A-INT.PD20171001-01



1.Unique identification code of the product-type:	"BUTEM" Metal Ceiling Systems
2.Type, batch or serial number or any other element allowing identification of the construction product as required pursuant to Article 11 (4):	Product Type, Order/Batch Nr.
3.Intended use or uses of the construction product, in accordance with the applicable harmonized technical specification, as foreseen by the manufacturer:	Internally, to produce an installed suspended ceiling
4.Name, registered trade name or registered trade mark and contact address of the manufacturer as required pursuant to Article 11 (5):	BÜTEM METAL FORM SANAYİ TİCARET A.Ş. Osman Gazi Mahallesi Ziya Gökalp Caddesi No:10 Esenyurt Istanbul Turkey T:+90 (212)886 33 00 F:+90 (212) 886 33 10 www.butemmetal.com.tr
5.Where applicable, name and contact address of the authorized representative whose mandate covers the tasks specified in Article 12 (2):	Not Applicable
6.System or systems of assessment and verification of constancy of performance of the construction product as set out in Annex V:	Systems 3
7.In case of the declaration of performance concerning a construction product covered by a harmonized standard:	(a)The manufacturer carrying out factory production control; (b) Turkish Standards Institution (TSE) /Notified Body No:1783 issued the Reaction to Fire classification report (Report No:TSE-19.01.2017-170050) according to TS EN 13501-1+A1:2013-04 as the notified testing laboratory (based on sampling carried out by the manufacturer).
8.In case of the declaration of performance concerning a construction product for which a European Technical Assessment has been issued:	Not Applicable

Declaration of Performance



No:A-INT.PD20171001-01

9.Declared Performance

- (a) Column 1 shall contain the list of essential characteristics as determined in the harmonized technical specifications for the intended use or uses indicated in point 3 above.
- (b) For each essential characteristic listed in column 1 and in compliance with the requirements of Article 6, Column 2 shall contain the declared performance, expressed by level or class, or in a description, related to the corresponding essential characteristics. The letters 'NPD' (No Performance Determined) shall be indicated where no performance is declared.
- (c) For each essential characteristic listed in column 1, column 3 shall contain:
- I-Dated reference of the corresponding harmonized standard and, where relevant, the reference number of the Specific or Appropriate Technical Documentation used; or
 - II-Dated reference of the corresponding European Assessment Document where available and reference number of the European Technical Assessment used.

Essential Characteristics	Performance	Harmonized Technical Specification
Reaction To fire	A2-s1, d0	TS EN 13964:2014-04 + TS EN13501-1+A1:2010
Release of Dangerous Substances	No Content	TS EN 13964:2014-04 + TS EN13501-1+A1:2010
Flexural Tensile Strength	NPD	TS EN 13964:2014-04 + TS EN13501-1+A1:2010
Thermal Conductivity	NPD	TS EN 13964:2014-04 + TS EN13501-1+A1:2010
Durability	Corrosion Class B	TS EN 13964:2014-04 + TS EN13501-1+A1:2010
Sound Absorption Single Value aw	See Table Below	TS EN 13964:2014-04 + TS EN13501-1+A1:2010

Sound Absorption Single Value aw	Perforation Types		
	Ø1,5 mm	Ø1,8 mm	Ø2,5 mm
JM 60	-	0,35	0,35
Royalin R6/60	0,60		
JM 60 Double	0,45		
JM60 with 25 mm 50 kg/m ³ rockwool	1,00		

- 10.The performance of the product identified in point 1 and 2 is in conformity with he declared performance in point 9.
 This declaration of performance is issued under the sole responsibility of the manufacturer identified in point 4.