

T70 SİSTEM

T70 SİSTEM

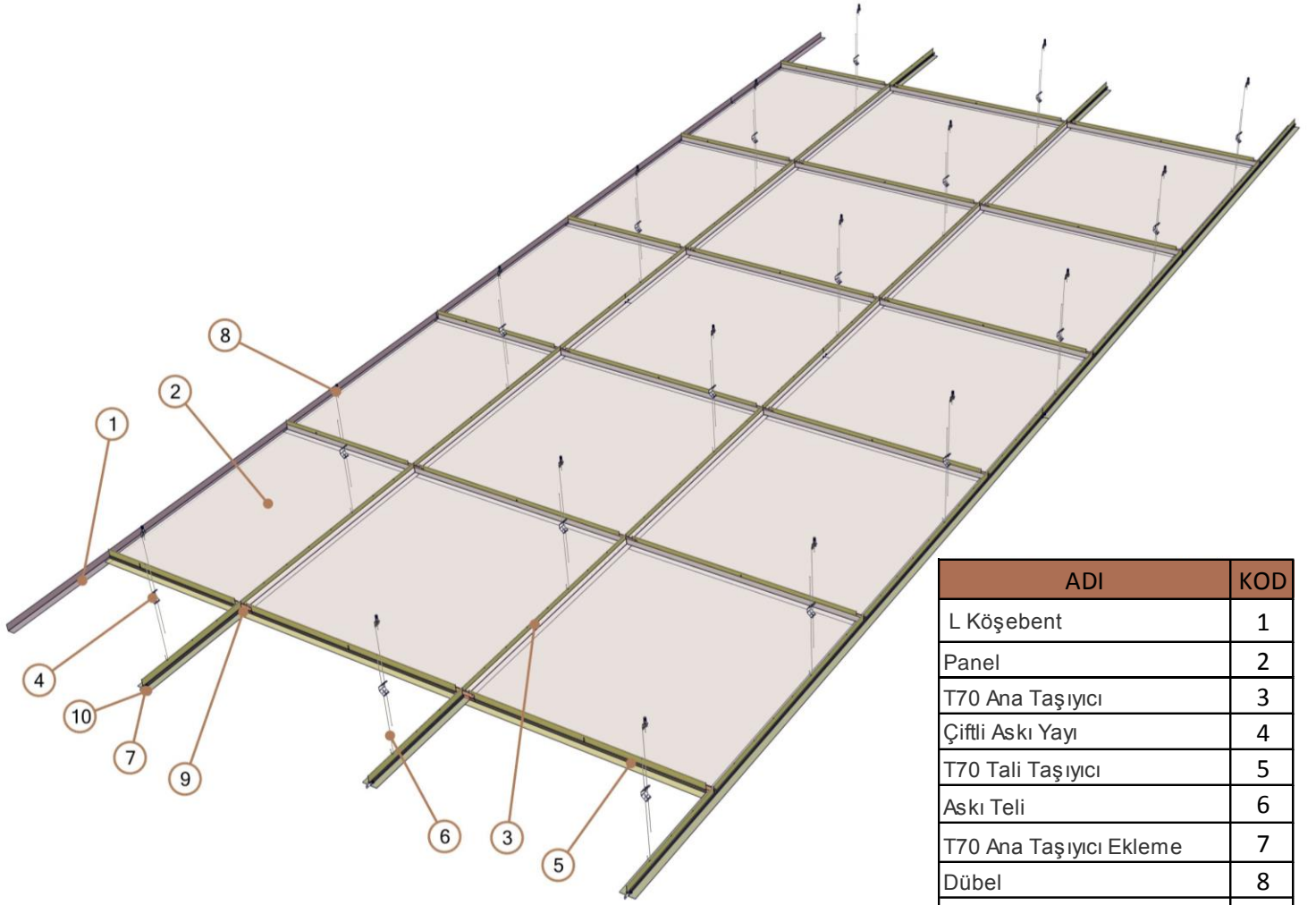

ADI	KOD
L Köşebent	1
Panel	2
T70 Ana Taşıyıcı	3
Çiftli Askı Yayı	4
T70 Tali Taşıyıcı	5
Askı Teli	6
T70 Ana Taşıyıcı Ekleme	7
Dübel	8
T70 Tali Taşıyıcı Ekleme	9
Vida Seti	10

- Alüminyum ekstrüzyon taşıyıcı sistem olması sayesinde, taşıyıcı boylarında istenen ayarlama yapılabildiğinden, her çeşit panel ölçüsüne uygun hale getirilebilir
- Bu sistem daha çok büyük ebatlı panellerde tercih edilmektedir.
- Taşyünü, Alçı gibi diğer tip panellerle de kullanılabilir.

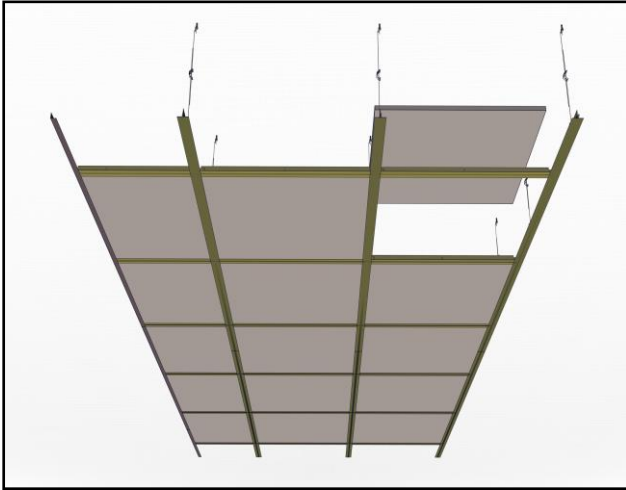
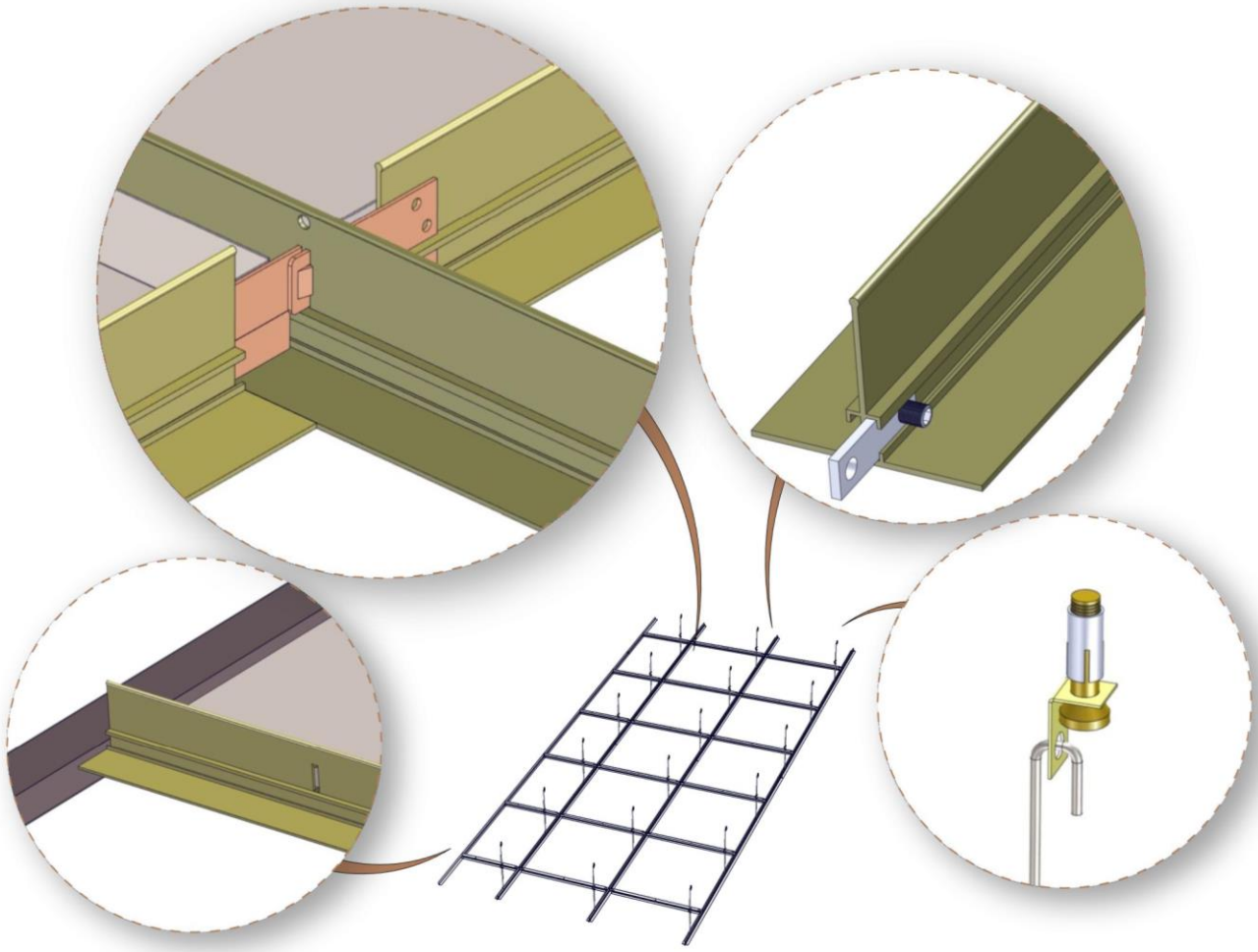

PANEL MALZEME SEÇENEKLERİ

Galvaniz Çelik/Alüminyum/Paslanmaz Çelik

AKUSTİK

Akustik kumaş ile α_w : 1,00 e kadar yüksek ses yutma değerleri

NEM / HUMIDITY

Galvaniz panel : 90% RH
Alüminyum panel : 100 % RH

IŞIK YANSITMA

Perforesiz : 9010 Boyalı % 86
Perforeli : 9010 Boyalı % 72

HİJYEN

Anti-Mikrobiyal boya sayesinde, panel yüzeyindeki bakteri oluşumunu engellemede yüksek performans sağlanır.

BOYA

Boya öncesinde, hassas yüzey temizliği ve fosfat kaplaması uygulanır. 6 robot kollu elektro static system sayesinde minimum 60 mikron boya panele uygulanır ve 180 mt uzunluğundaki fırında pişirilir. Tüm boyama işlemi otomatik olarak bilgisayar kontrolünde gerçekleşir.

SİSTEM PARÇALARI ÖZELLİKLERİ

1. L Köşebent

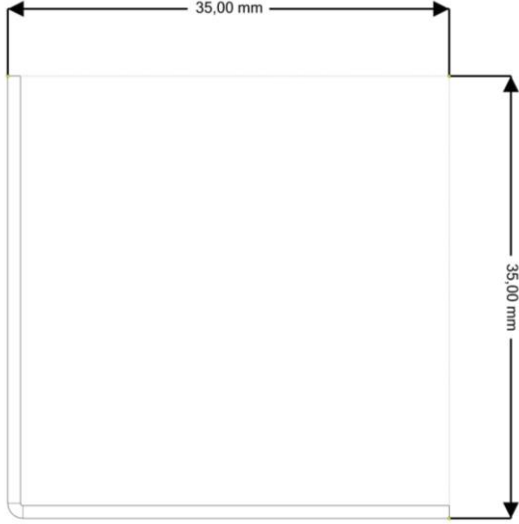

T : 1 mm Galvaniz Çelik
W : 35 mm H : 35 mm L : Up to 3000 mm

2. Panel

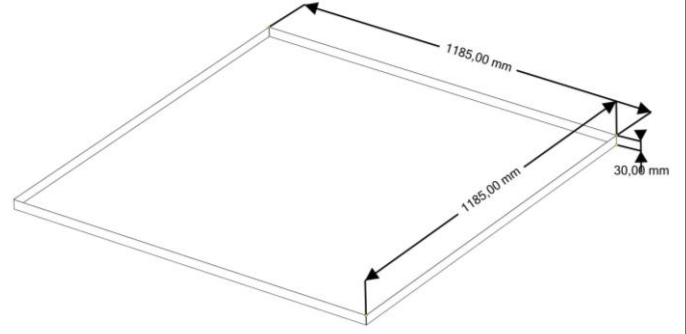

T : 0,50 mm Galvaniz Çelik / 0,60 mm Alüminyum
0,50 mm Paslanmaz Çelik

3. T70 Ana Taşıyıcı

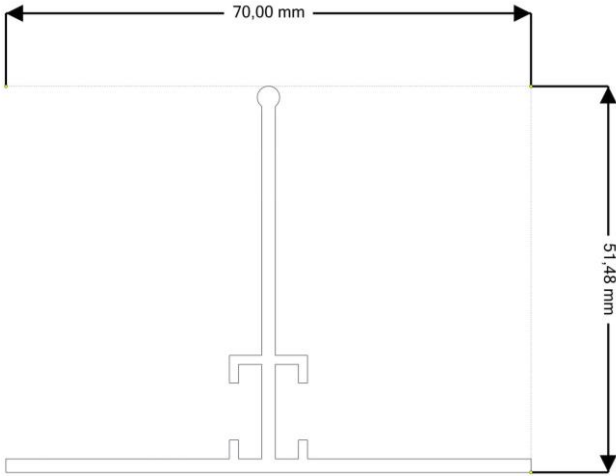

T : 1,20 mm Alüminyum
W : 70 mm H : 51,50 mm L : 3600 mm

4. Çiftli Askı Yayı

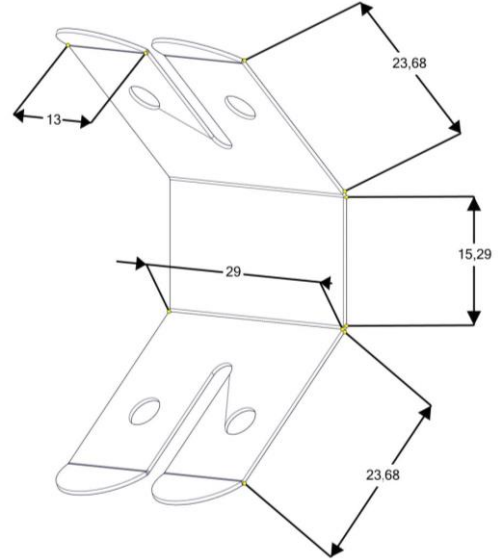

T : 0,50 mm Yay Çeliği

5. T70 Tali Taşıyıcı

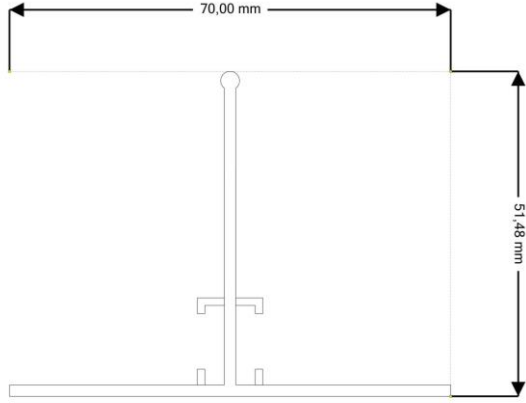

T : 1,20 mm Alüminyum
W : 70 mm H : 51,50 mm L : 1130 mm

6. Askı Teli



T : Ø 4 mm Galvaniz Çelik
L : Max 2000 mm

7. T70 Ana Taşıyıcı Ekleme

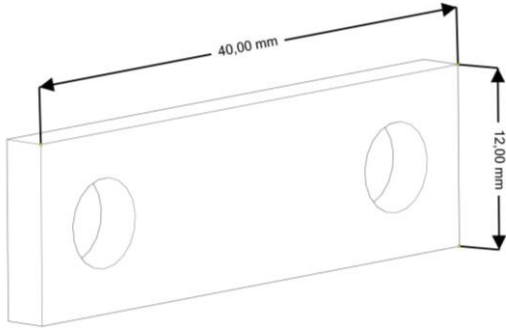

T : 3 mm Galvaniz Çelik
W : 40 mm H : 12 mm

8. Dübel

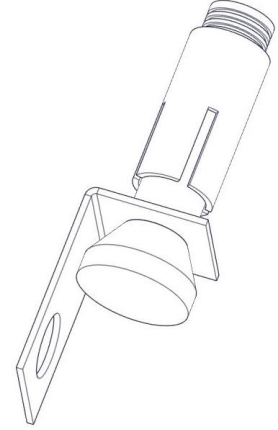

T : 0,8 mm / 2 mm / Ø 8 mm Galvaniz Çelik

9. T70 Tali Taşıyıcı Ekleme

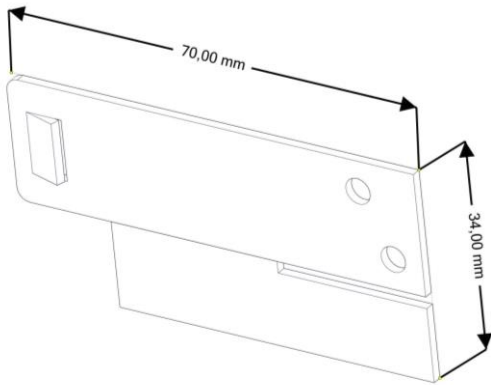

T : 1,50 mm Galvanized Steel
W : 70 mm H : 34 mm

10. Vida Seti

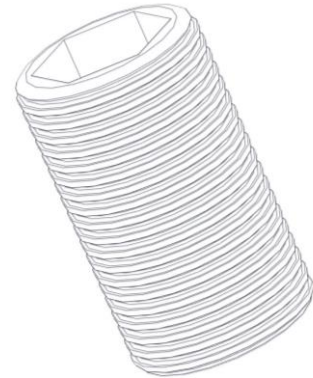

T : Ø 6 mm Steel

DETAYLI KESİT

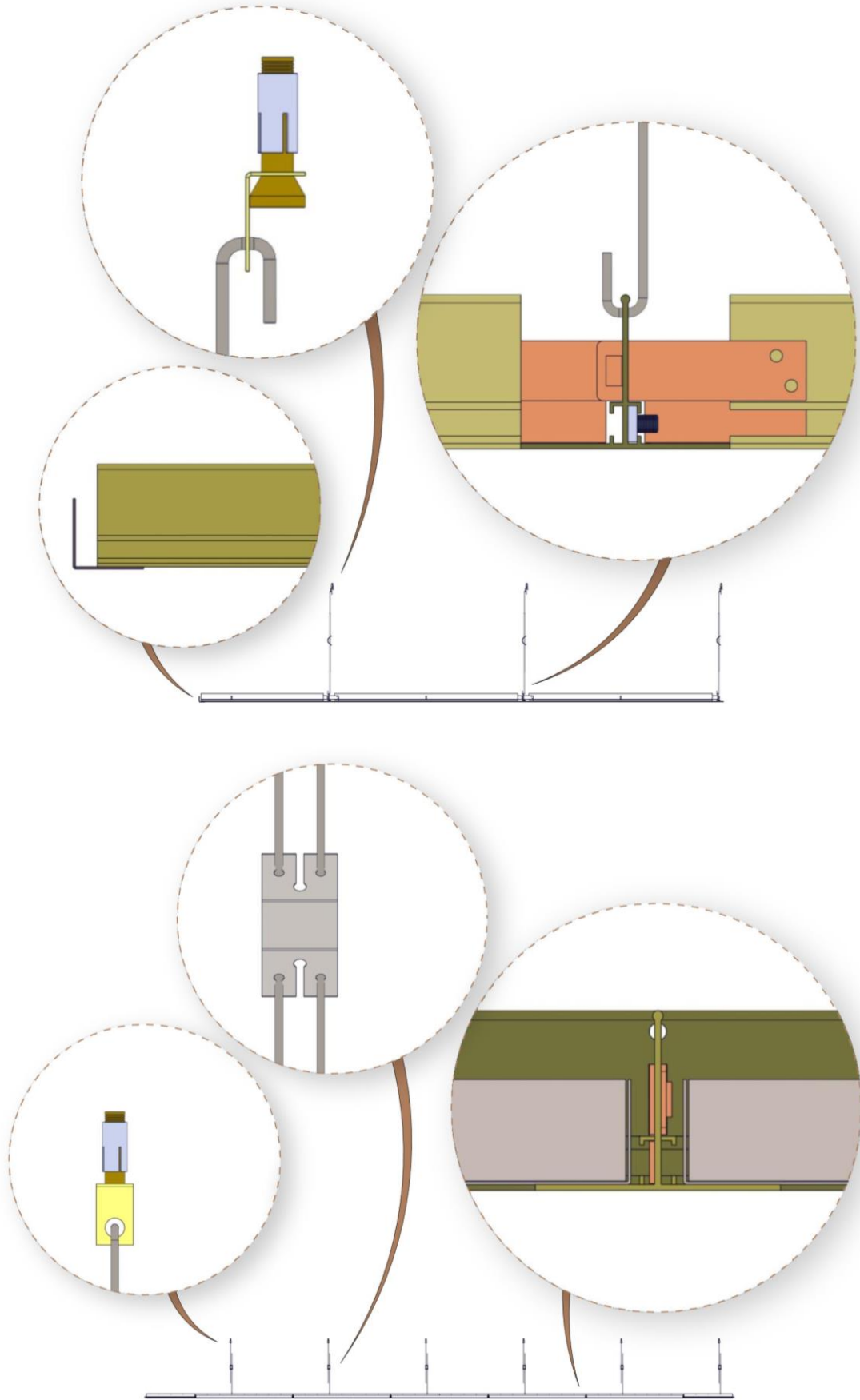

ADIM 1.

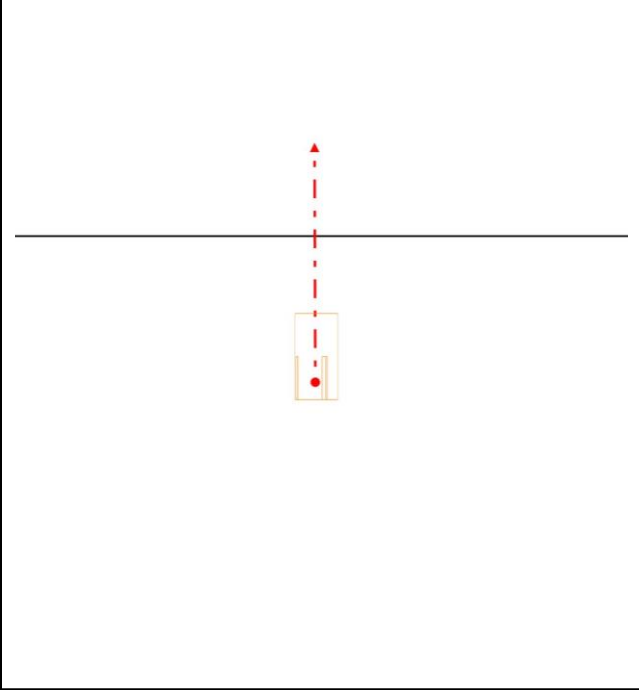

ADIM 2.

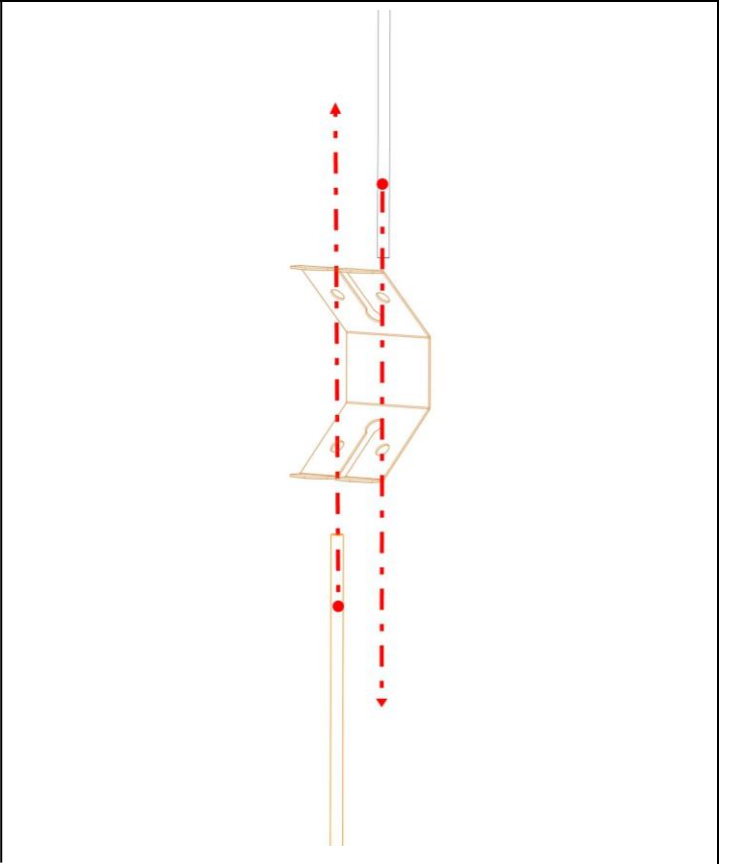
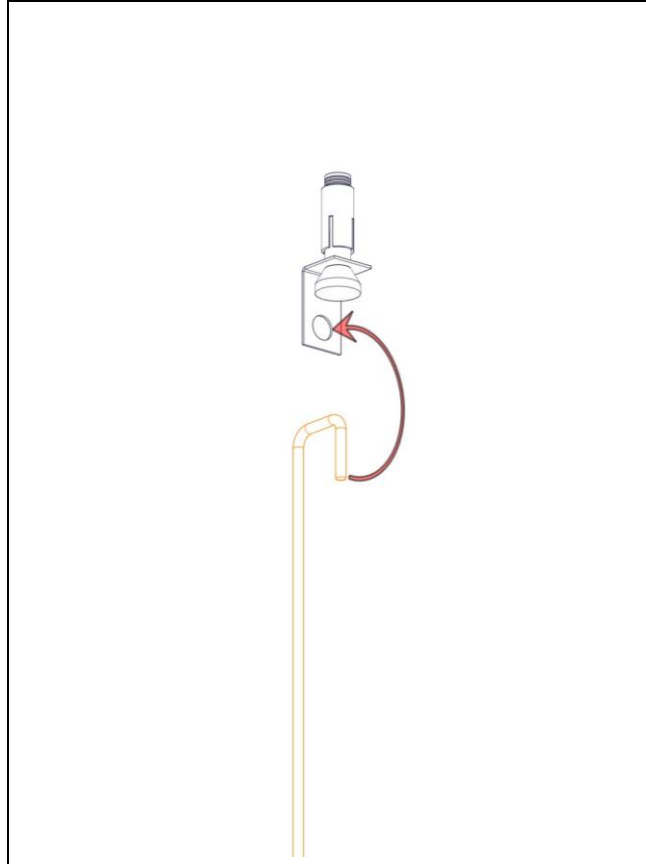
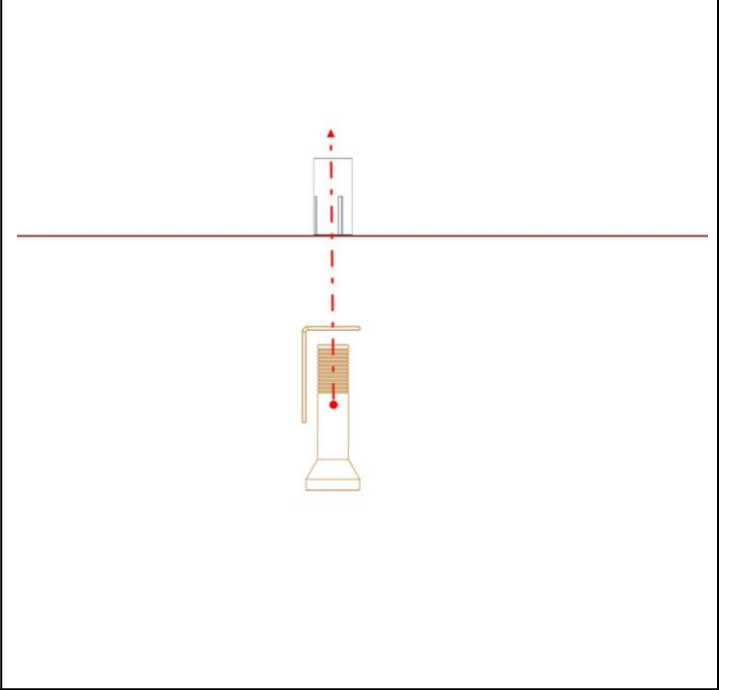

ADIM 3.

ADIM 4.

ADIM 5.

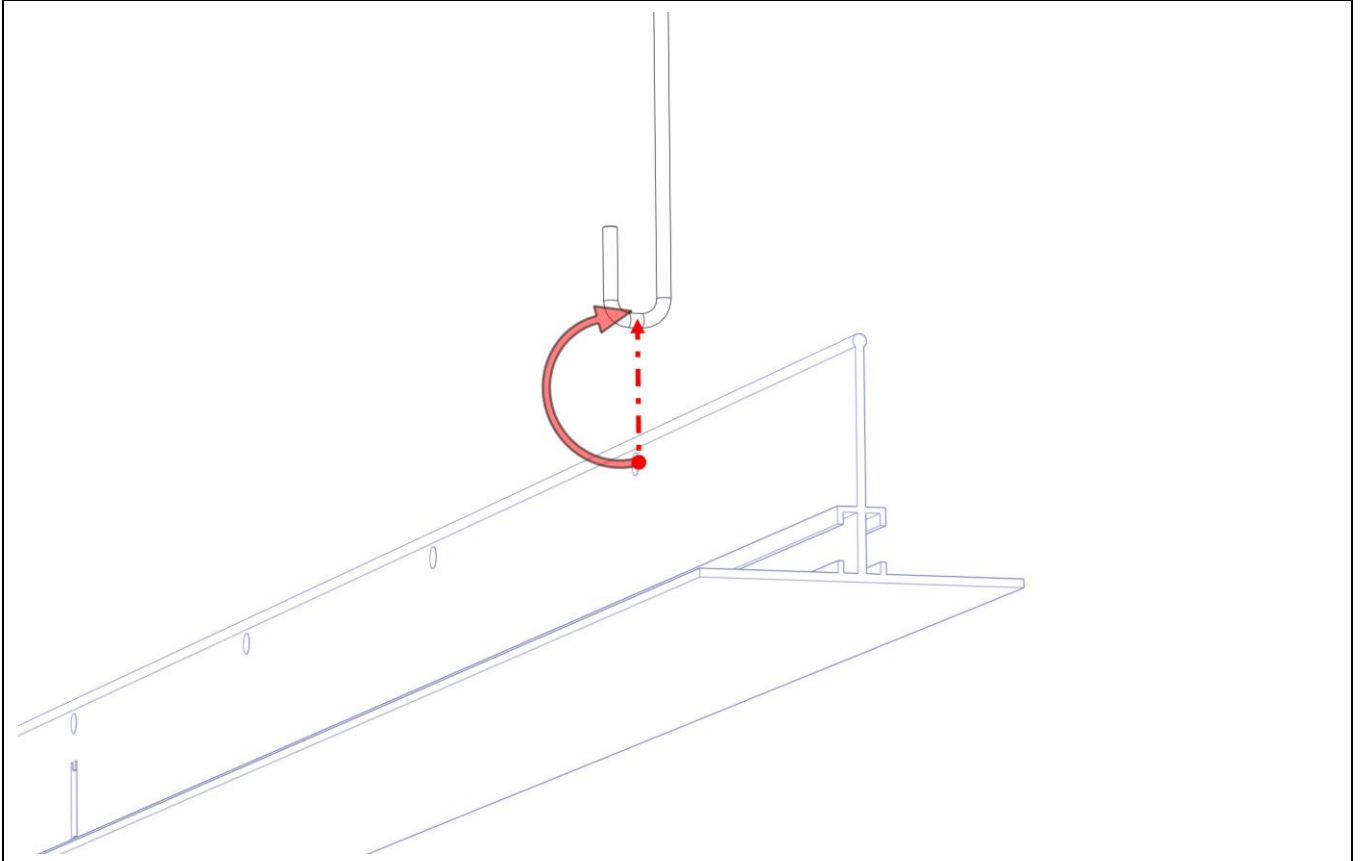
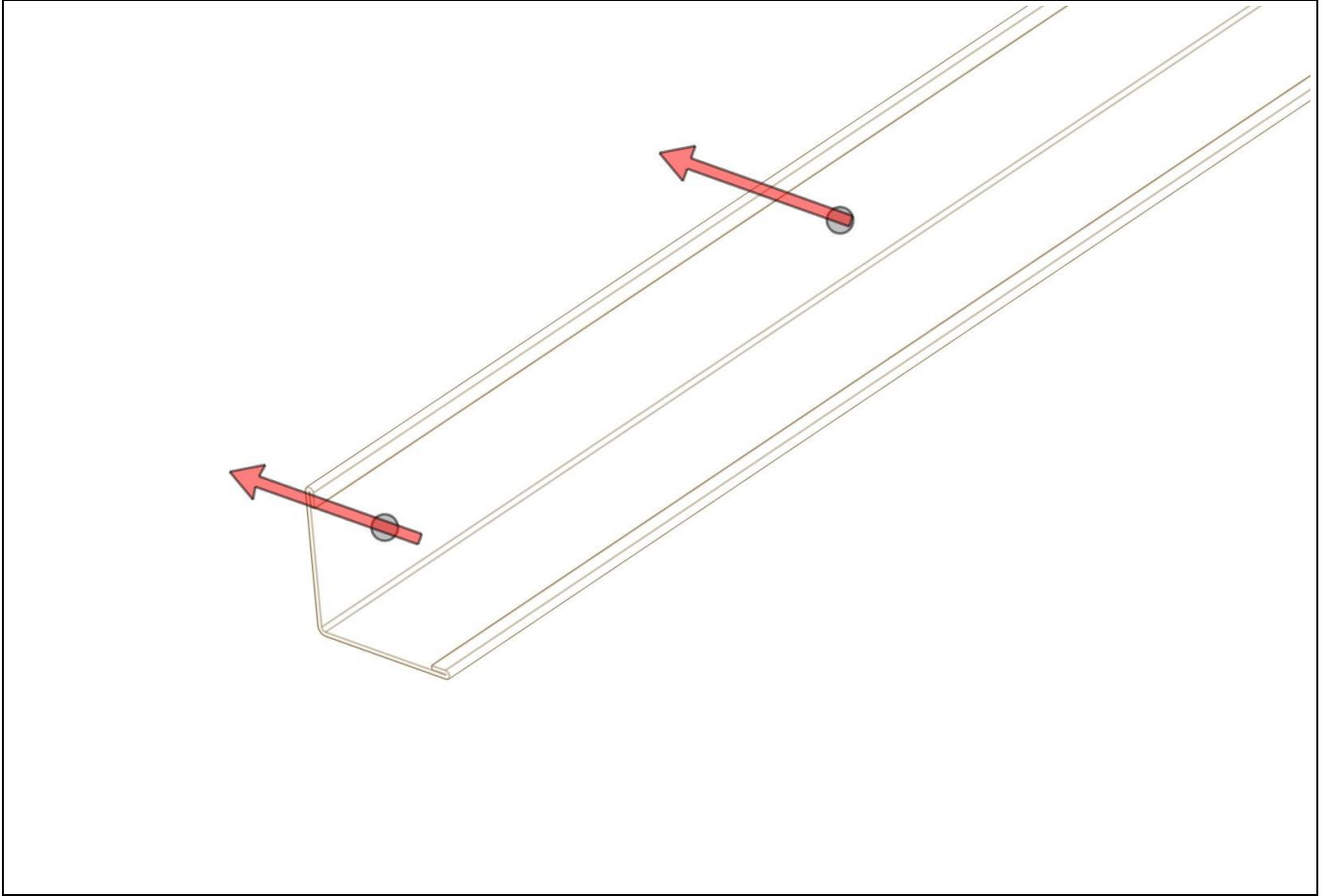

ADIM 6.

ADIM 7.

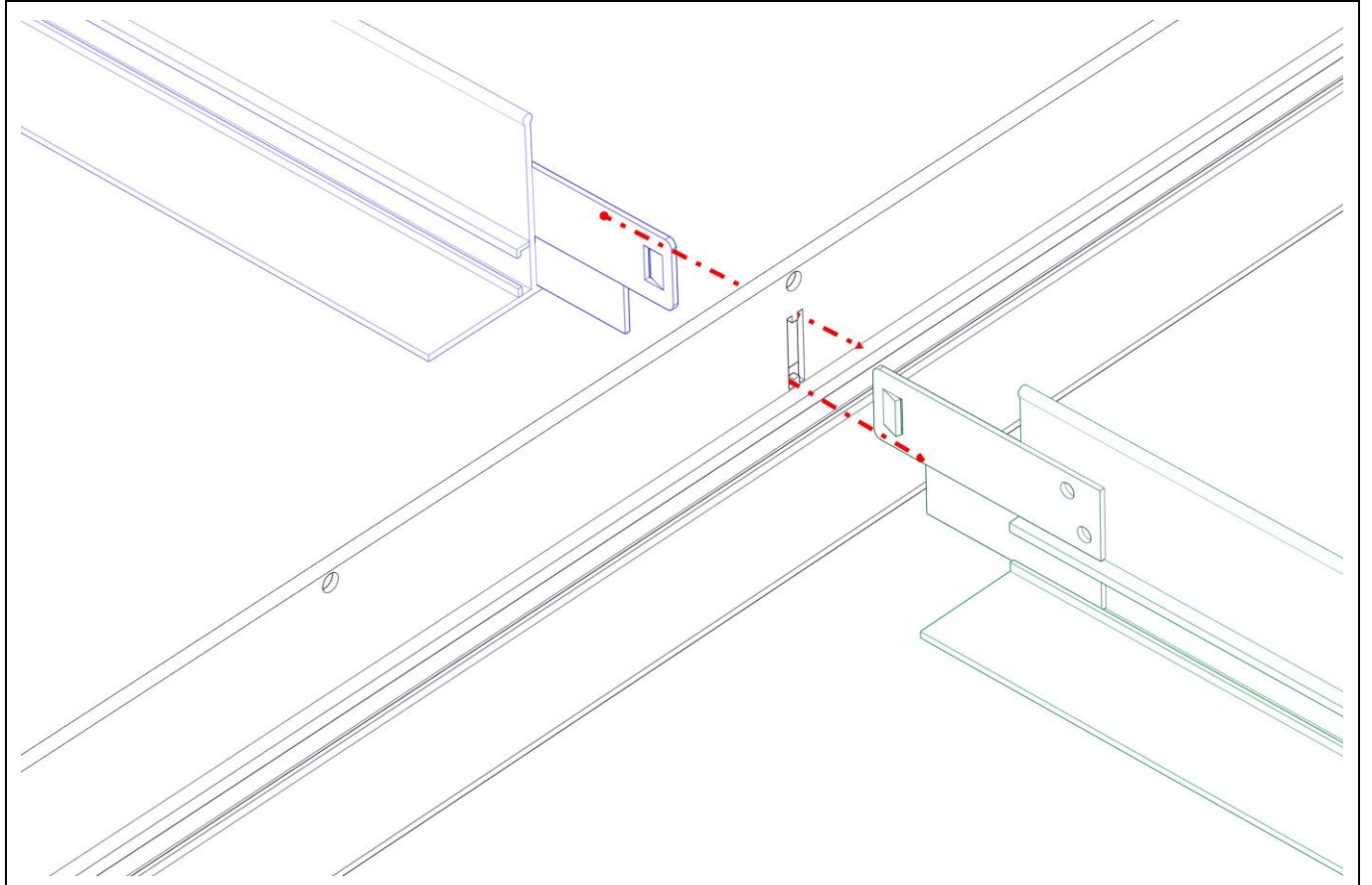
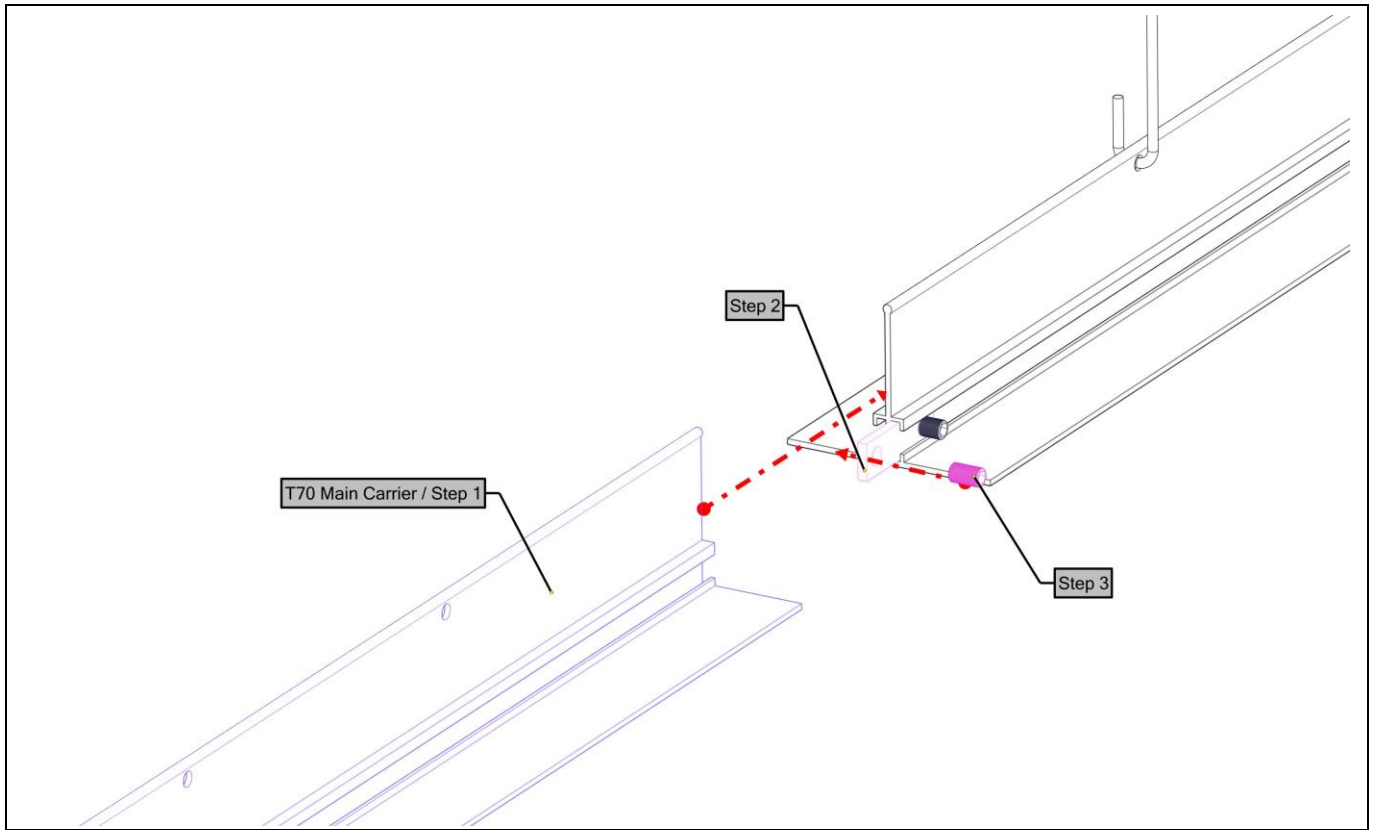

ADIM 8.

ADIM 9.

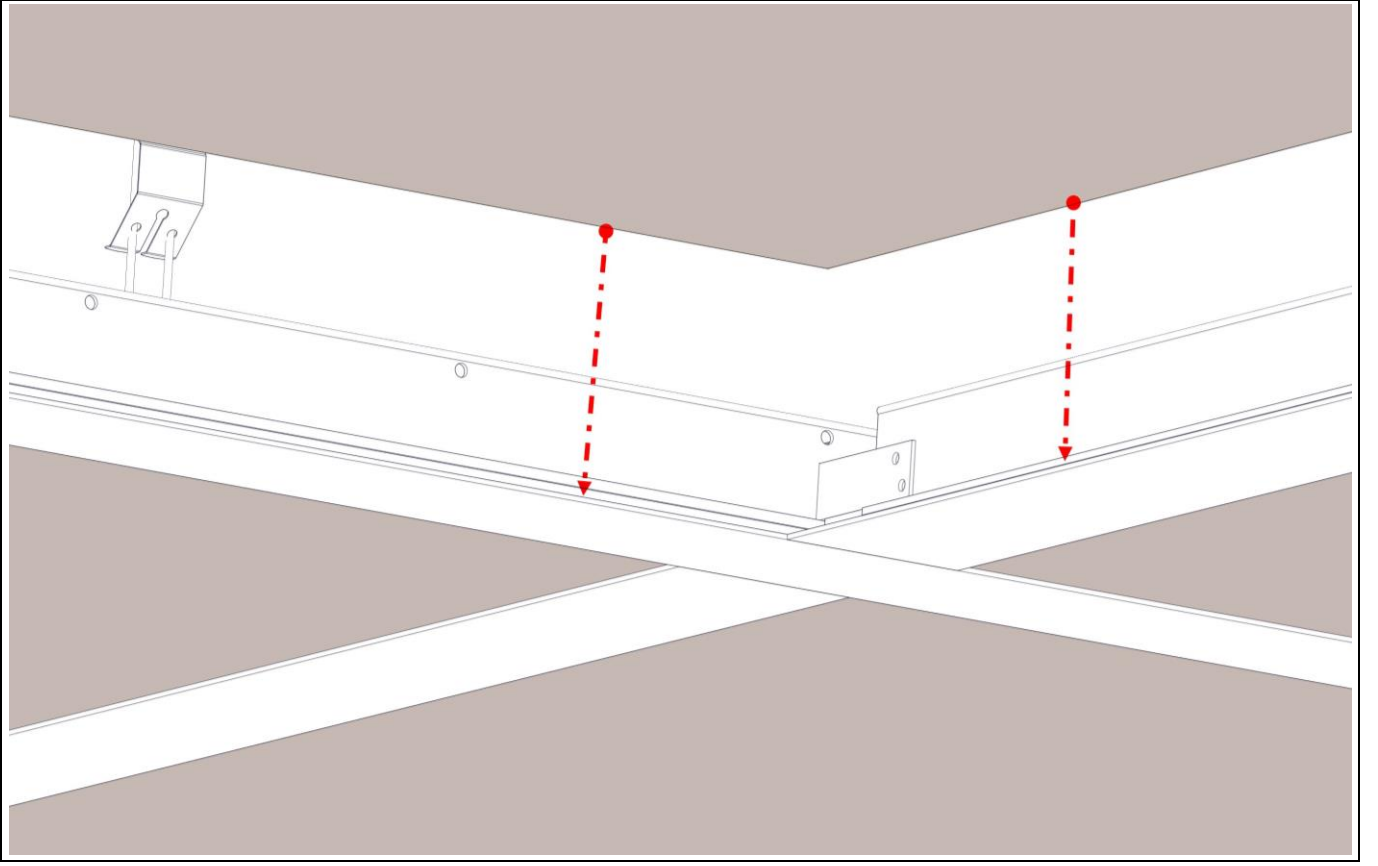

Declaration of Performance

No:A-INT.PD20171001-01



1.Uniquade identification code of the product-type:	"BUTEM" Metal Ceiling Systems
2.Type, batch or serial number or any other element allowing identification of the construction product as required pursuant to Article 11 (4):	Product Type, Order/Batch Nr.
3.Intended use or uses of the construction product, in accordance with the applicable harmonized technical specification, as foreseen by the manufacturer:	Internally, to produce an installed suspended ceiling
4.Name, registered trade name or registered trade mark and contact address of the manufacturer as required pursuant to Article 11 (5):	BÜTEM METAL FORM SANAYİ TİCARET A.Ş. Osman Gazi Mahallesi Ziya Gökalp Caddesi No:10 Esenyurt Istanbul Turkey T:+90 (212)886 33 00 F:+90 (212) 886 33 10 www.butemmetal.com.tr
5.Where applicable, name and contact address of the authorized representative whose mandate covers the tasks specified in Article 12 (2):	Not Applicable
6.System or systems of assessment and verification of constancy of performance of the construction product as set out in Annex V:	Systems 3
7.In case of the declaration of performance concerning a construction product covered by a harmonized standard:	(a)The manufacturer carrying out factory production control; (b) Turkish Standards Institution (TSE) /Notified Body No:1783 issued the Reaction to Fire classification report (Report No:TSE-19.01.2017-170050) according to TS EN 13501-1+A1:2013-04 as the notified testing laboratory (based on sampling carried out by the manufacturer).
8.In case of the declaration of performance concerning a construction product for which a European Technical Assessment has been issued:	Not Applicable

Declaration of Performance



No:A-INT.PD20171001-01

9.Declared Performance

- (a) Column 1 shall contain the list of essential characteristics as determined in the harmonized technical specifications for the intended use or uses indicated in point 3 above.
- (b) For each essential characteristic listed in column 1 and in compliance with the requirements of Article 6, Column 2 shall contain the declared performance, expressed by level or class, or in a description, related to the corresponding essential characteristics. The letters 'NPD' (No Performance Determined) shall be indicated where no performance is declared.
- (c) For each essential characteristic listed in column 1, column 3 shall contain:
- I-Dated reference of the corresponding harmonized standard and, where relevant, the reference number of the Specific or Appropriate Technical Documentation used; or
 - II-Dated reference of the corresponding European Assessment Document where available and reference number of the European Technical Assessment used.

Essential Characteristics	Performance	Harmonized Technical Specification
Reaction To fire	A2-s1, d0	TS EN 13964:2014-04 + TS EN13501-1+A1:2010
Release of Dangerous Substances	No Content	TS EN 13964:2014-04 + TS EN13501-1+A1:2010
Flexural Tensile Strength	NPD	TS EN 13964:2014-04 + TS EN13501-1+A1:2010
Thermal Conductivity	NPD	TS EN 13964:2014-04 + TS EN13501-1+A1:2010
Durability	Corrosion Class B	TS EN 13964:2014-04 + TS EN13501-1+A1:2010
Sound Absorption Single Value a_w	See Table Below	TS EN 13964:2014-04 + TS EN13501-1+A1:2010

Sound Absorption Single Value a_w	Perforation Types		
	Ø1,5 mm	Ø1,8 mm	Ø2,5 mm
JM 60	-	0,35	0,35
Royalin R6/60	0,60		
JM 60 Double	0,45		
JM60 with 25 mm 50 kg/m ³ rockwool	1,00		

10.The performance of the product identified in point 1 and 2 is in conformity with he declared performance in point 9.

This declaration of performance is issued under the sole responsibility of the manufacturer identified in point 4.