

DEMONTABLE  
SYSTEM

# DEMONTABLE SYSTEM

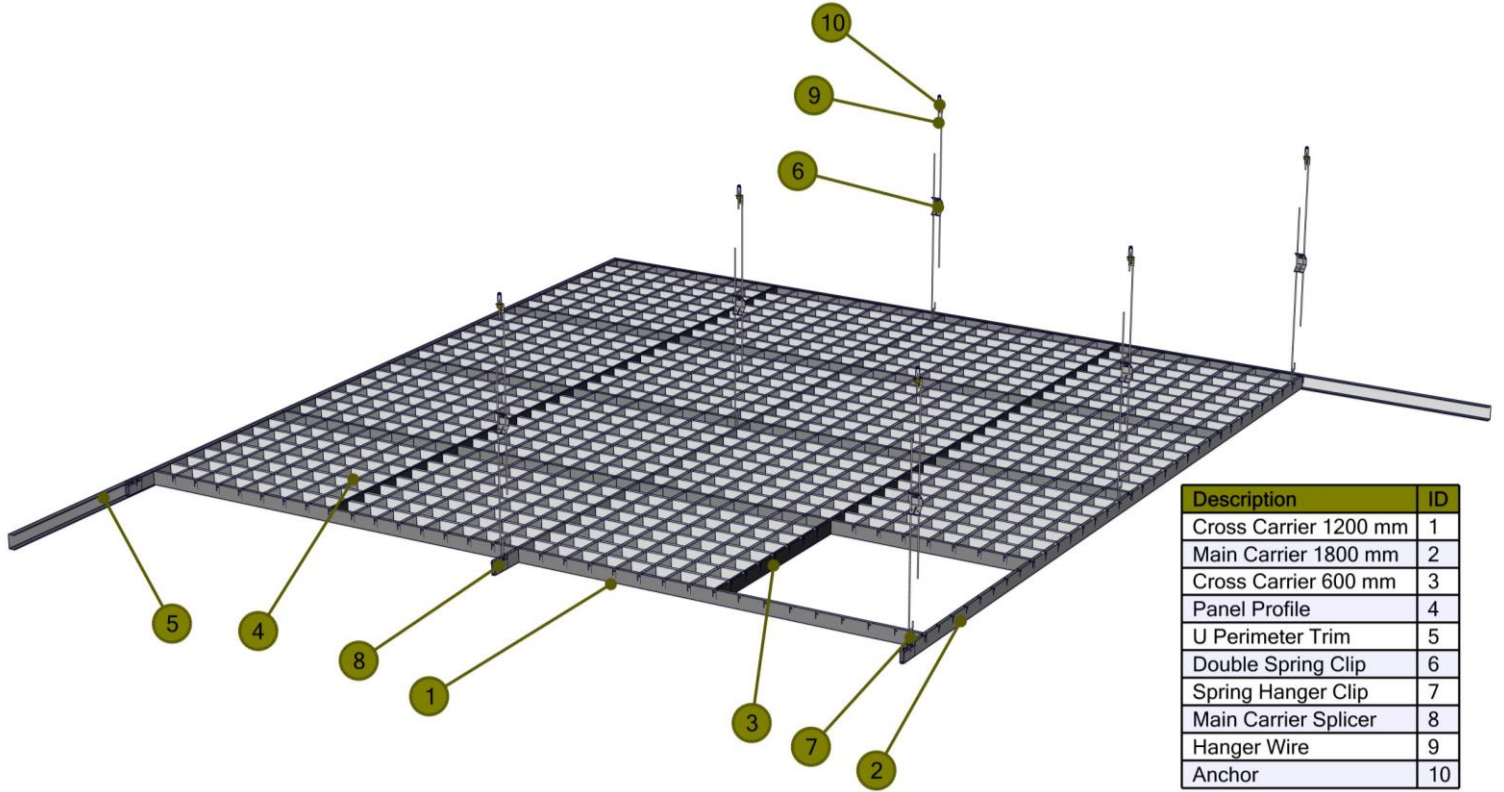

- **Standard Cell Size Alternatives : 100 mm - 75 mm - 50 mm.**  
different cell size are also possible. Please contact to your Sales Rep.
- **Standard height of profile is 40 mm, but 50 mm is also available on demand.**

# DETAIL VIEW

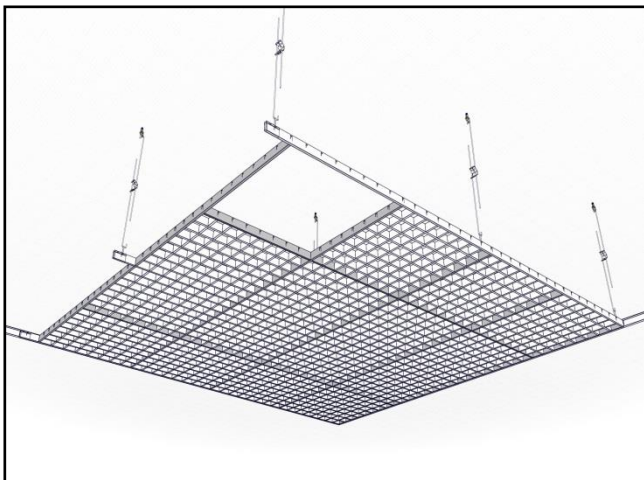
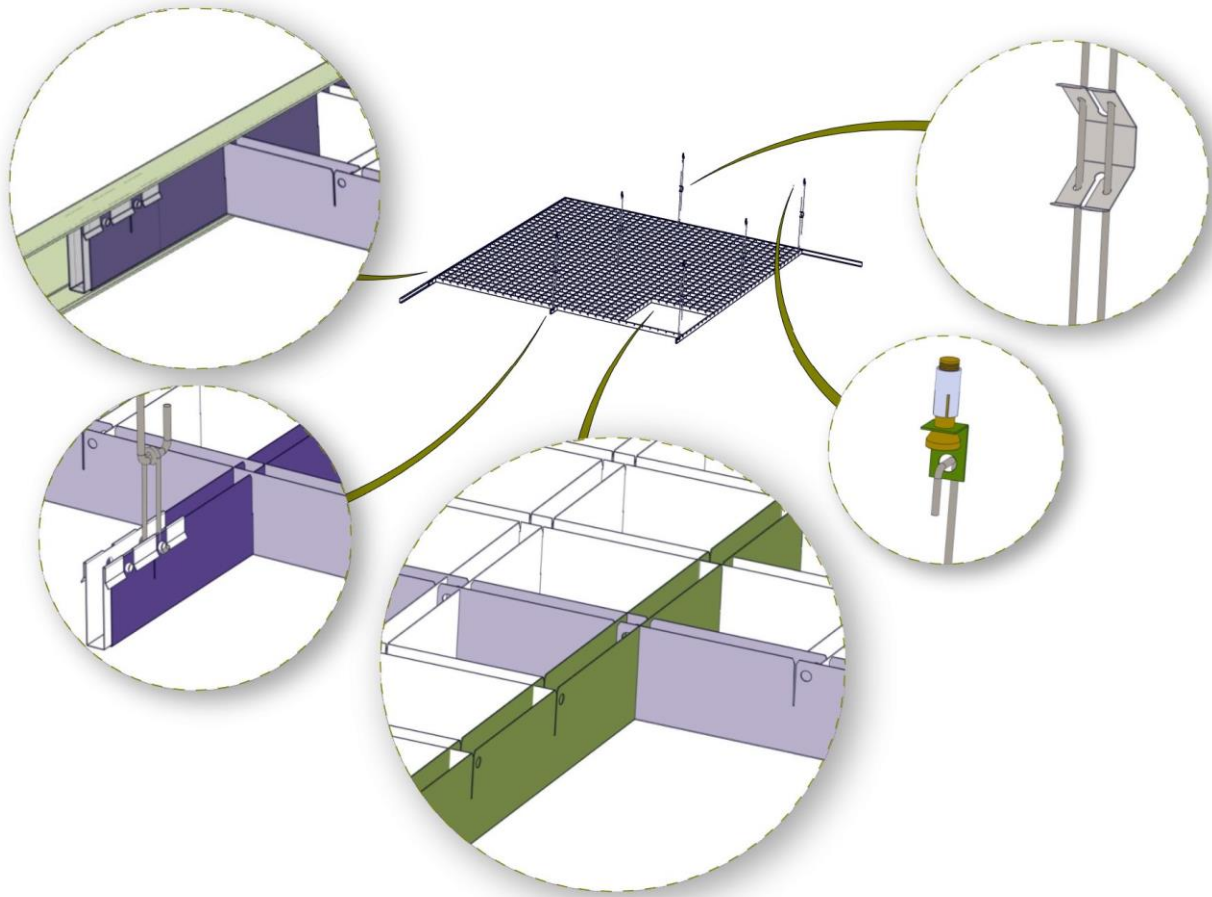

## MATERIAL OPTIONS

Galvanized Steel/Aluminum

## ACOUSTIC

With additional blanket

## HUMIDITY

Galvanize panel: 90% RH

Aluminum panel: 100 % RH

## HYGIENE

High performance in Blocking bacterial formation on panel surfaces by applying anti-microbial paint.

## PAINT

Pre-painted or electro static paint or wood-a-like finish options are available. Prior to paint. Sensitive surface cleaning and phosphate coverage is applied. 60 minimum micron powder paint is sprayed by electrostatic system through 6 robots and cooked in a 180 meters long oven. The entire painting process takes place automatically by computer control.

# ELEMENT SPECIFICATION

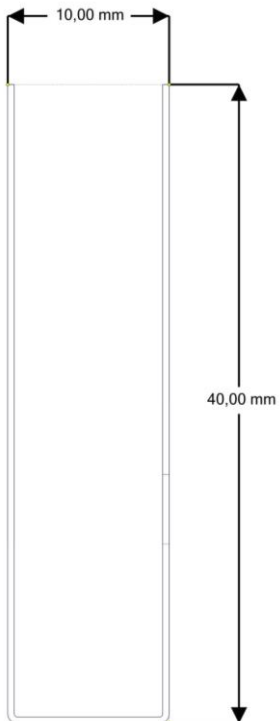
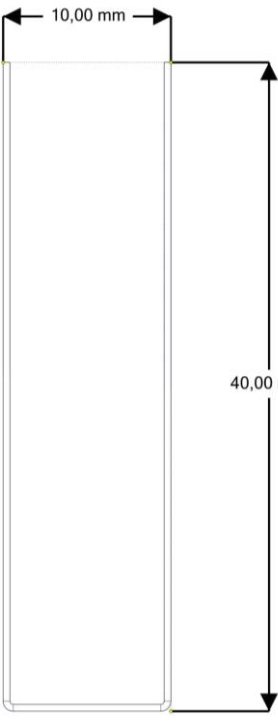
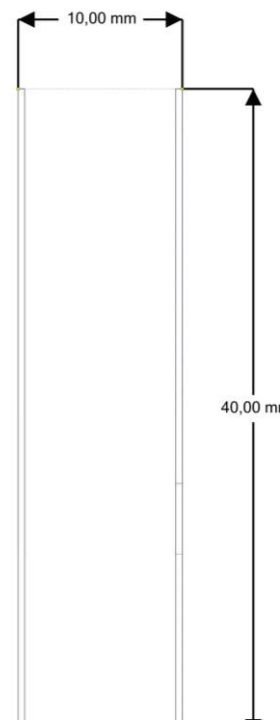
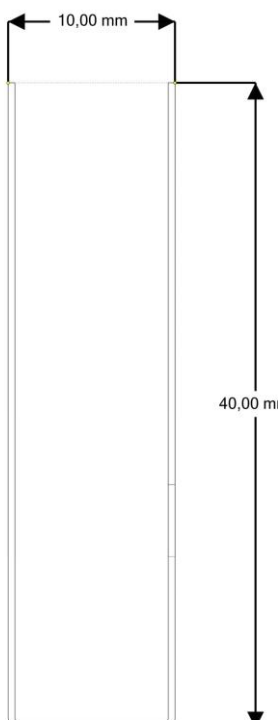
<p><b>1. Cross Carrier 1200 mm</b></p> 	<p><b>2. Main Carrier 1800 mm</b></p> 
<p><b>T : 0,40 mm Aluminum Steel</b> <b>W : 10 mm H : 40 mm L : 1200 mm</b></p>	<p><b>T : 0,40 mm Aluminum Steel</b> <b>W : 10 mm H : 40 mm L : 1800 mm</b></p>
<p><b>3. Cross Carrier 600 mm</b></p> 	<p><b>4. Panel Profile</b></p> 
<p><b>T : 0,40 mm Aluminum Steel</b> <b>W : 10 mm H : 40 mm L : 600 mm</b></p>	<p><b>T : 0,40 mm Aluminum Steel</b> <b>W : 10 mm H : 40 mm L : 600 mm</b></p>



### 5. U Perimeter Trim

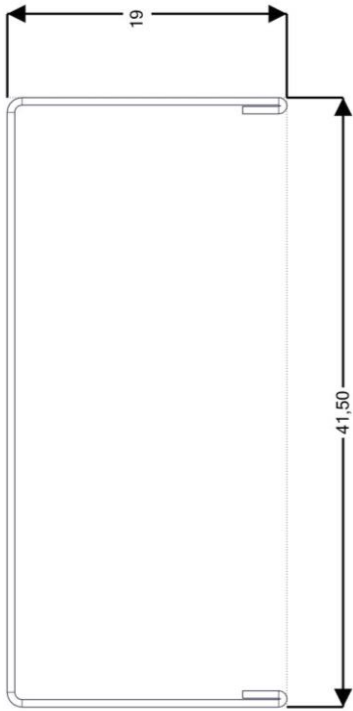

T : 0,4 mm Pre-Paint Steel  
W : 19 mm H : 41,50 mm L : Up to 3000 mm

### 6. Double Spring Clip

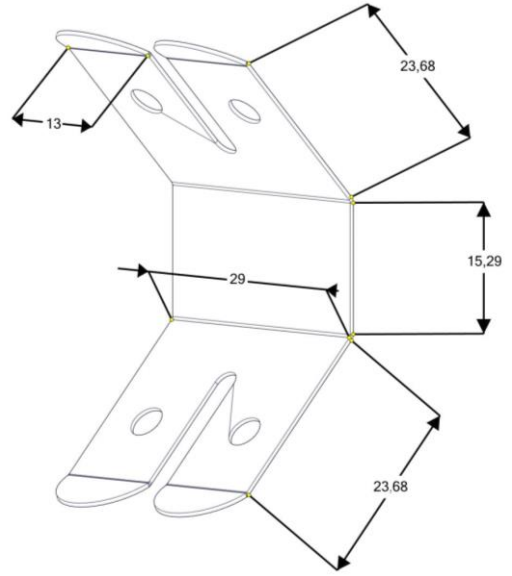

T : 0,50 mm Spring Steel

### 7. Spring Hanger Clip

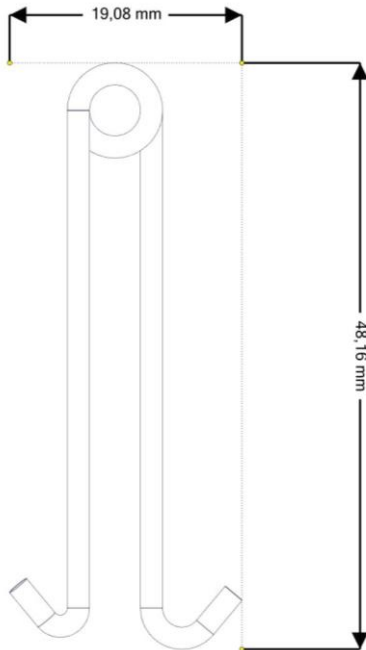

T : Ø 1,80 mm Steel  
W : 19 mm H : 48 mm

### 8. Main Carrier Splicer

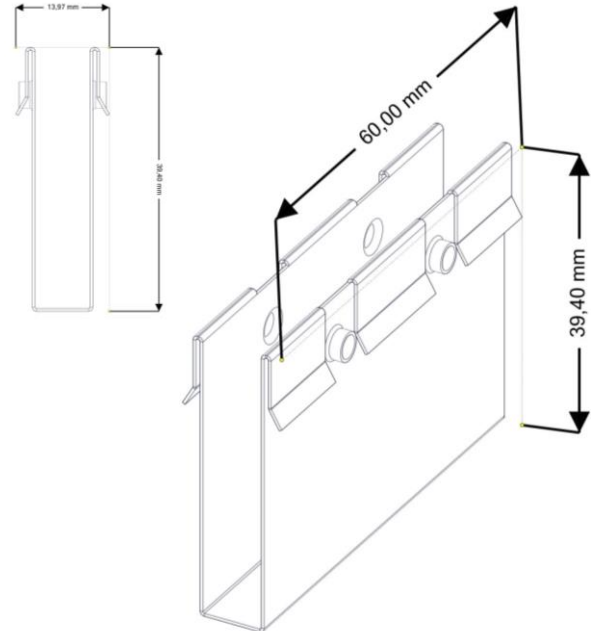

T : 0,4 mm Aluminum / Steel  
W : 14 mm H : 39,50 mm L : 60 mm

## 9. Hanger Wire

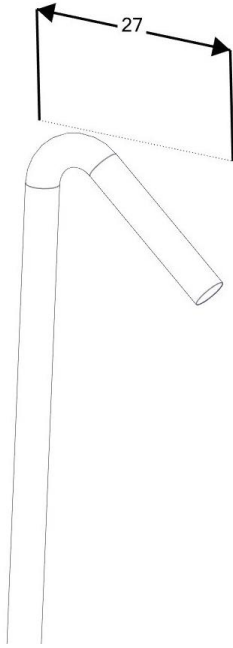

T : Ø 4 mm Galvanized Steel  
L : Max 2000 mm

## 10. Anchor

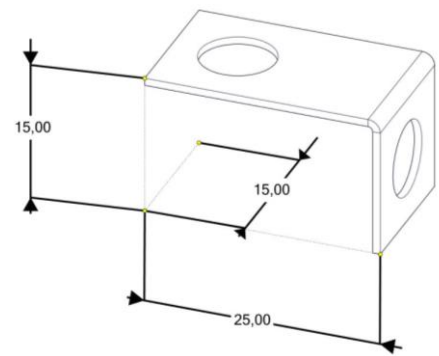
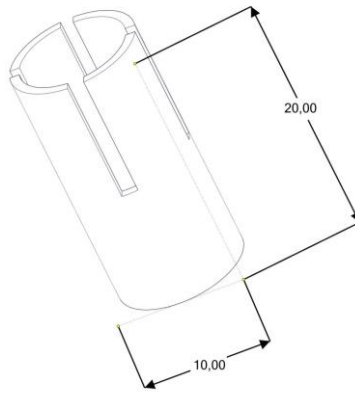
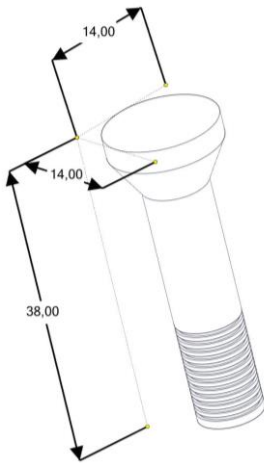
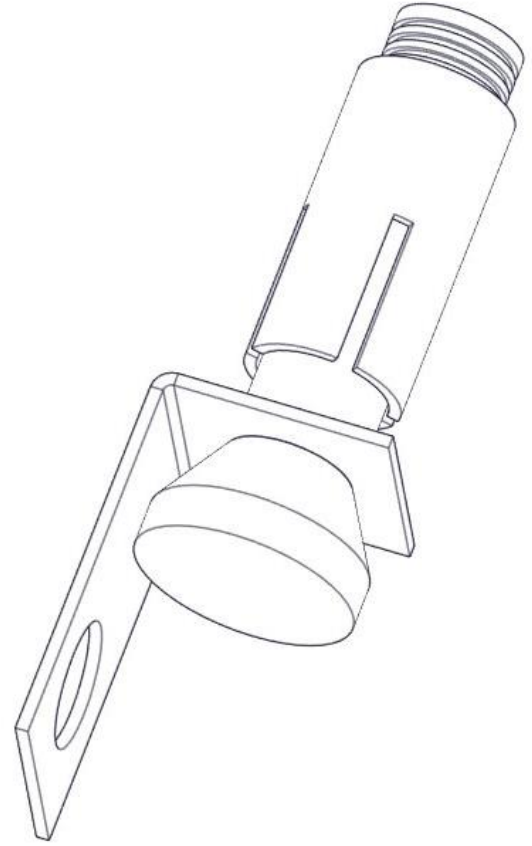

T : 0,2 mm / 0,8 mm / Ø 8 mm Galvanized Steel

# DETAIL SECTION

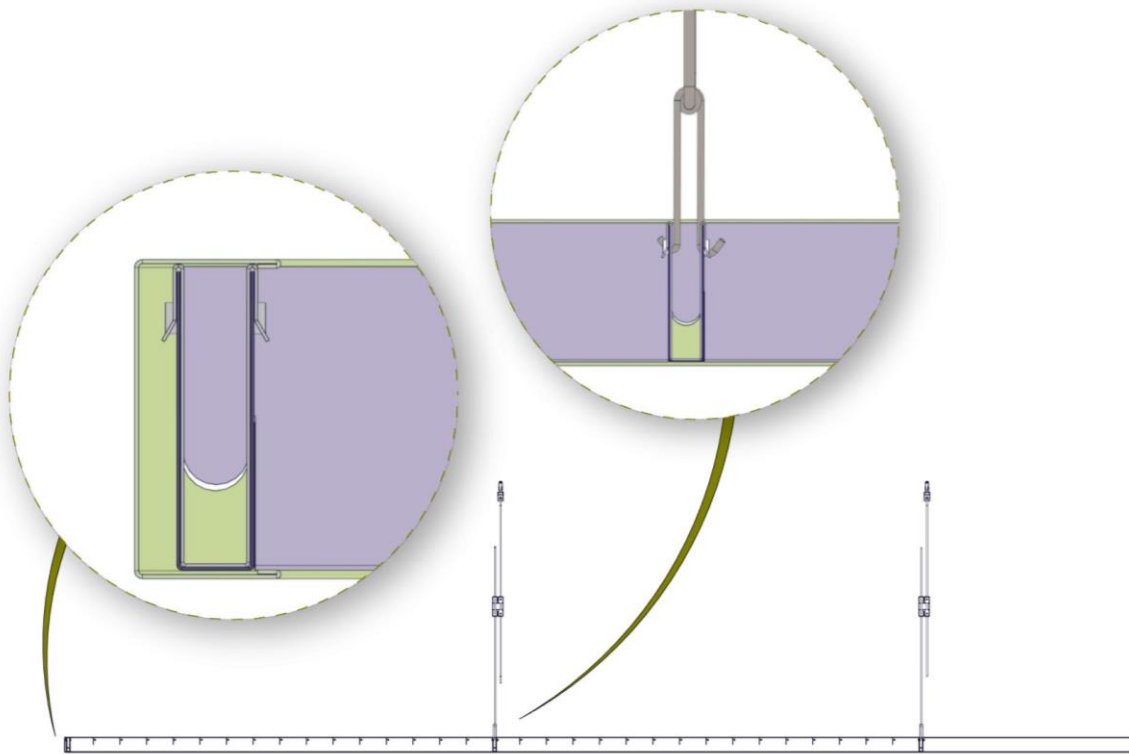
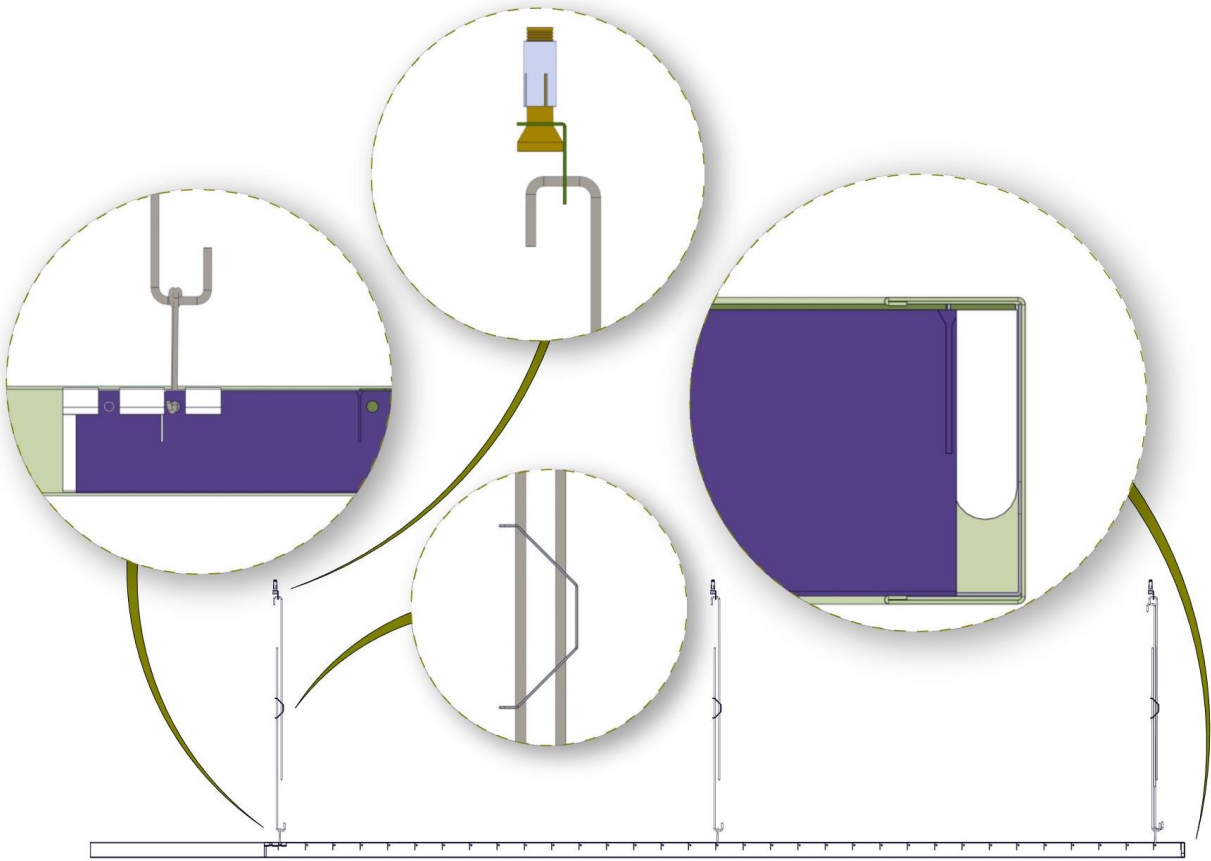

# ASSEMBLY TECHNIQUE

STEP 1.

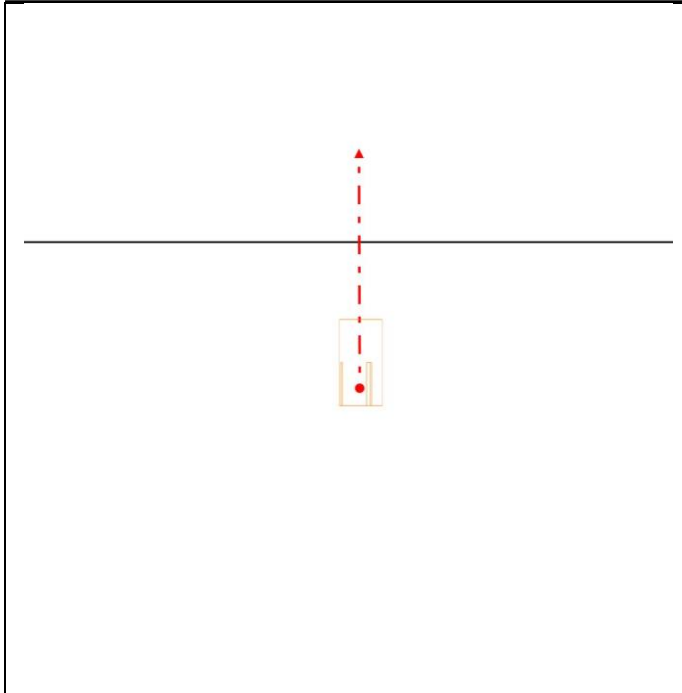

STEP 2.

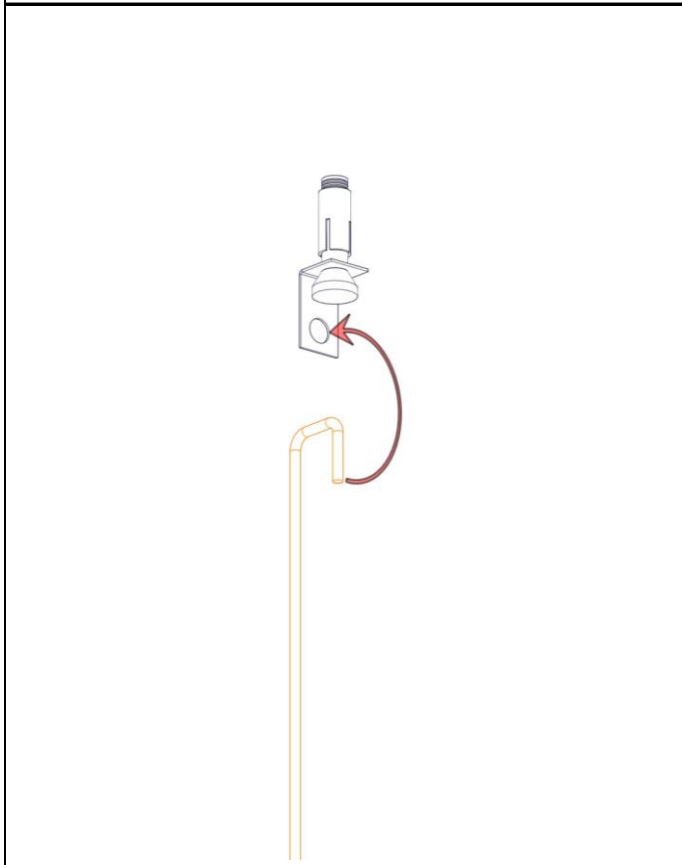
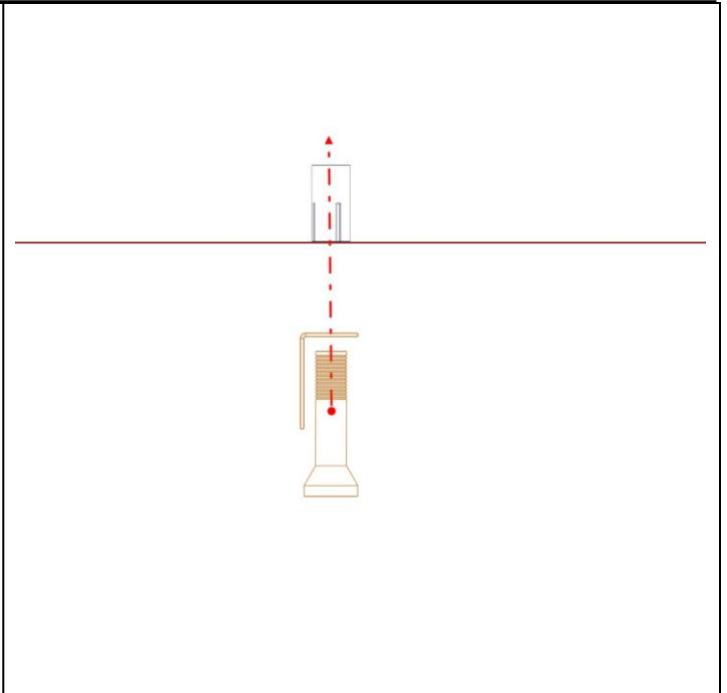

STEP 3.

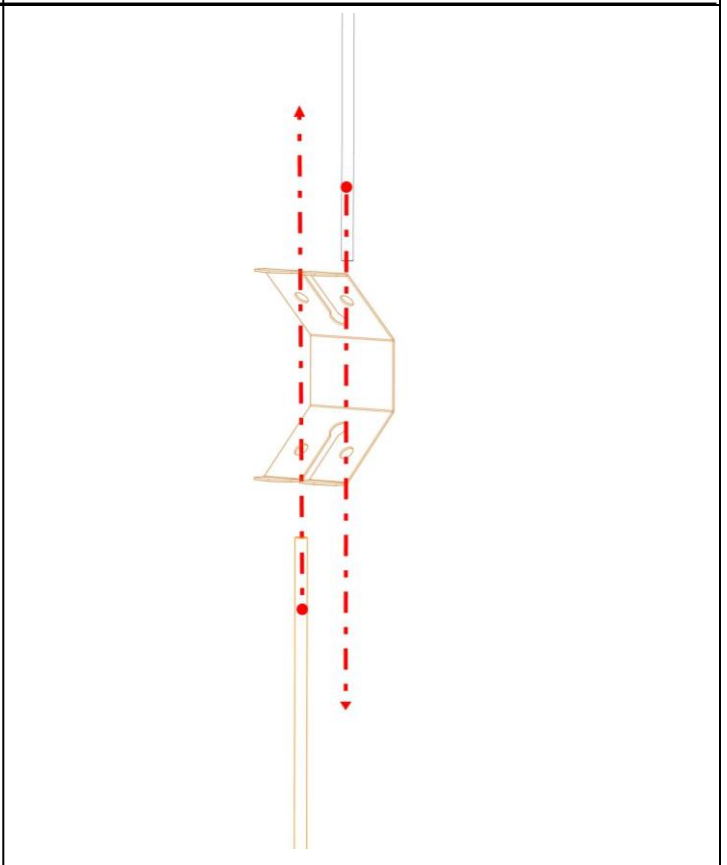

STEP 4.



STEP 5.

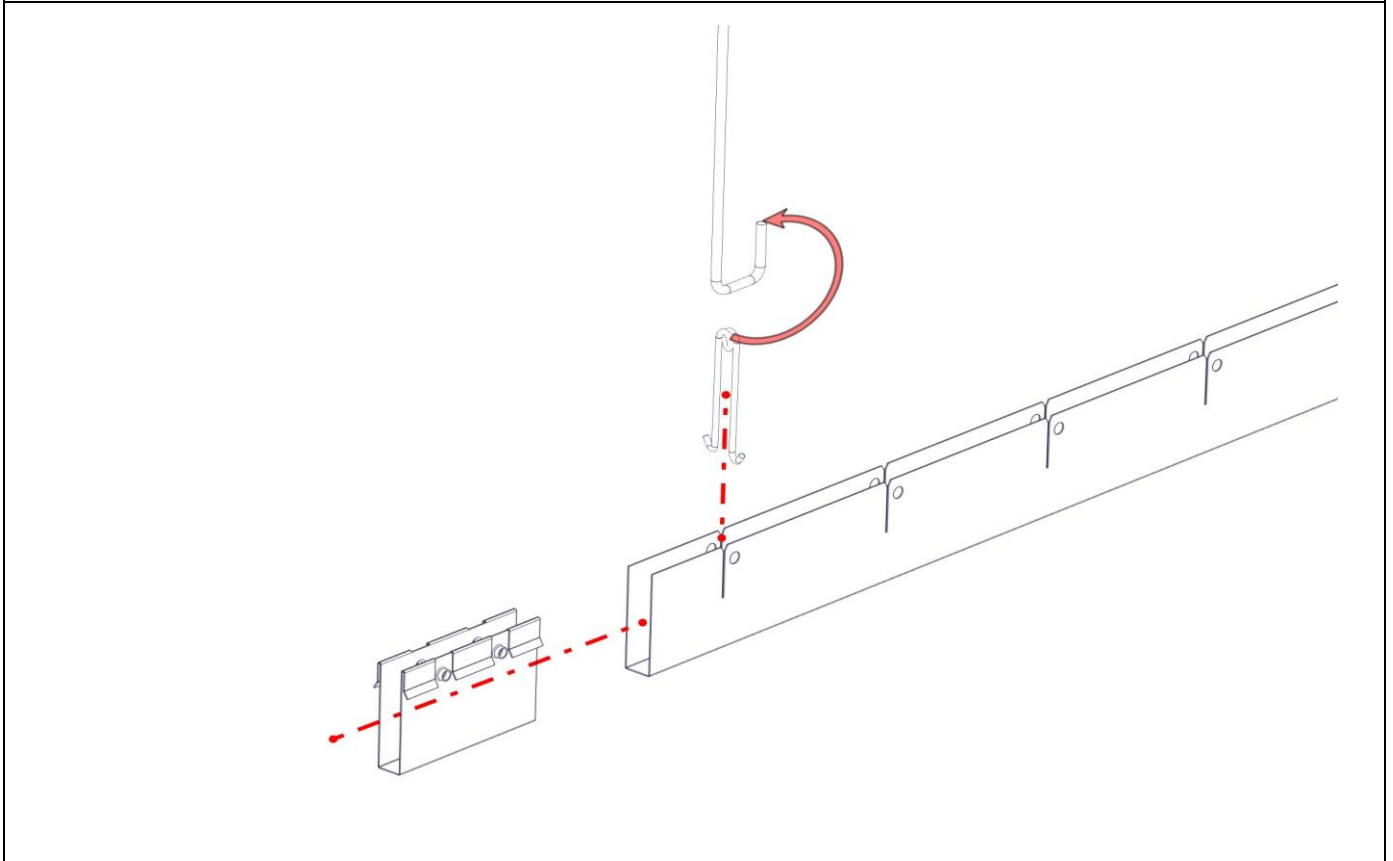
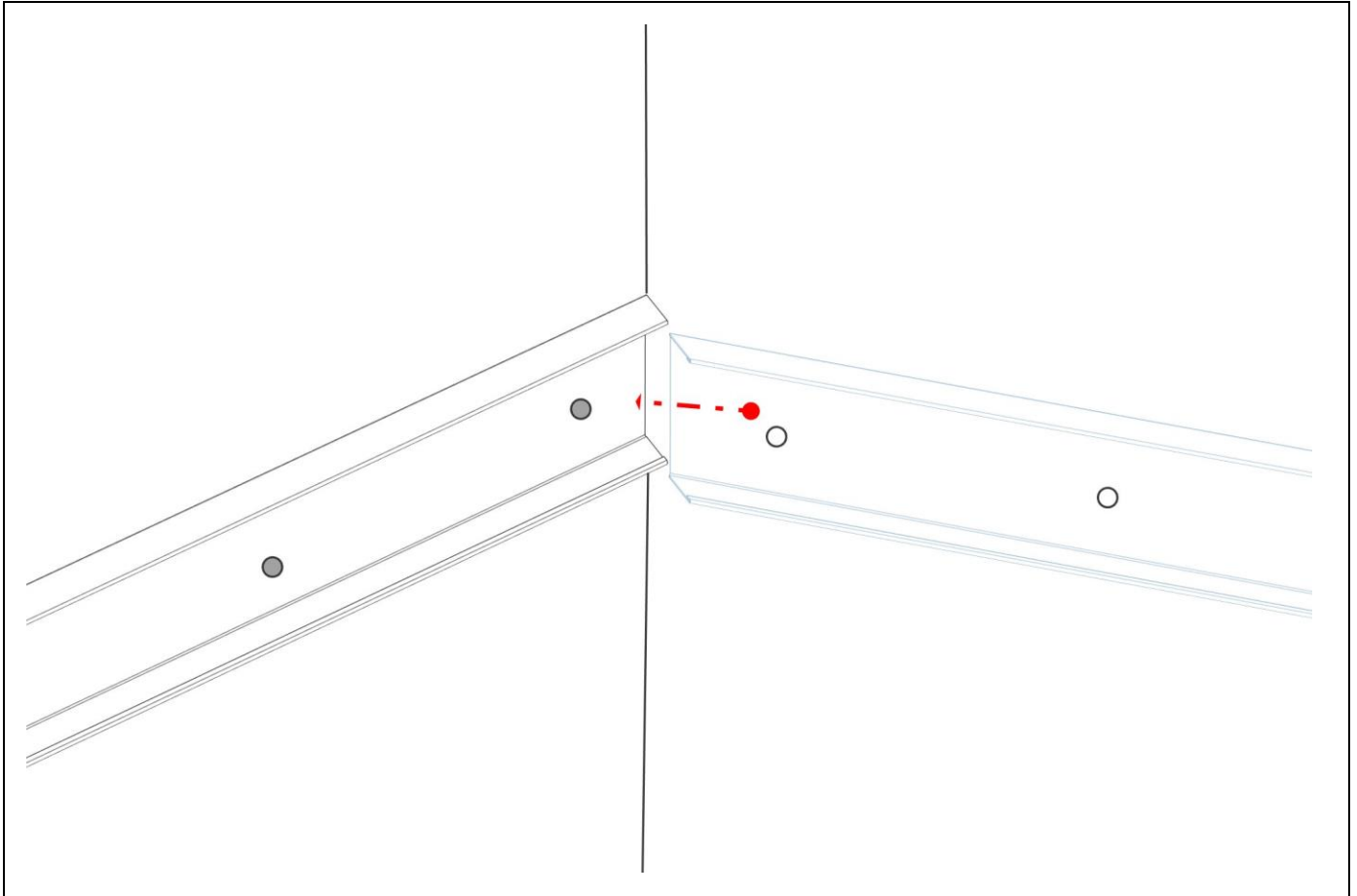

STEP 6.

STEP 7.

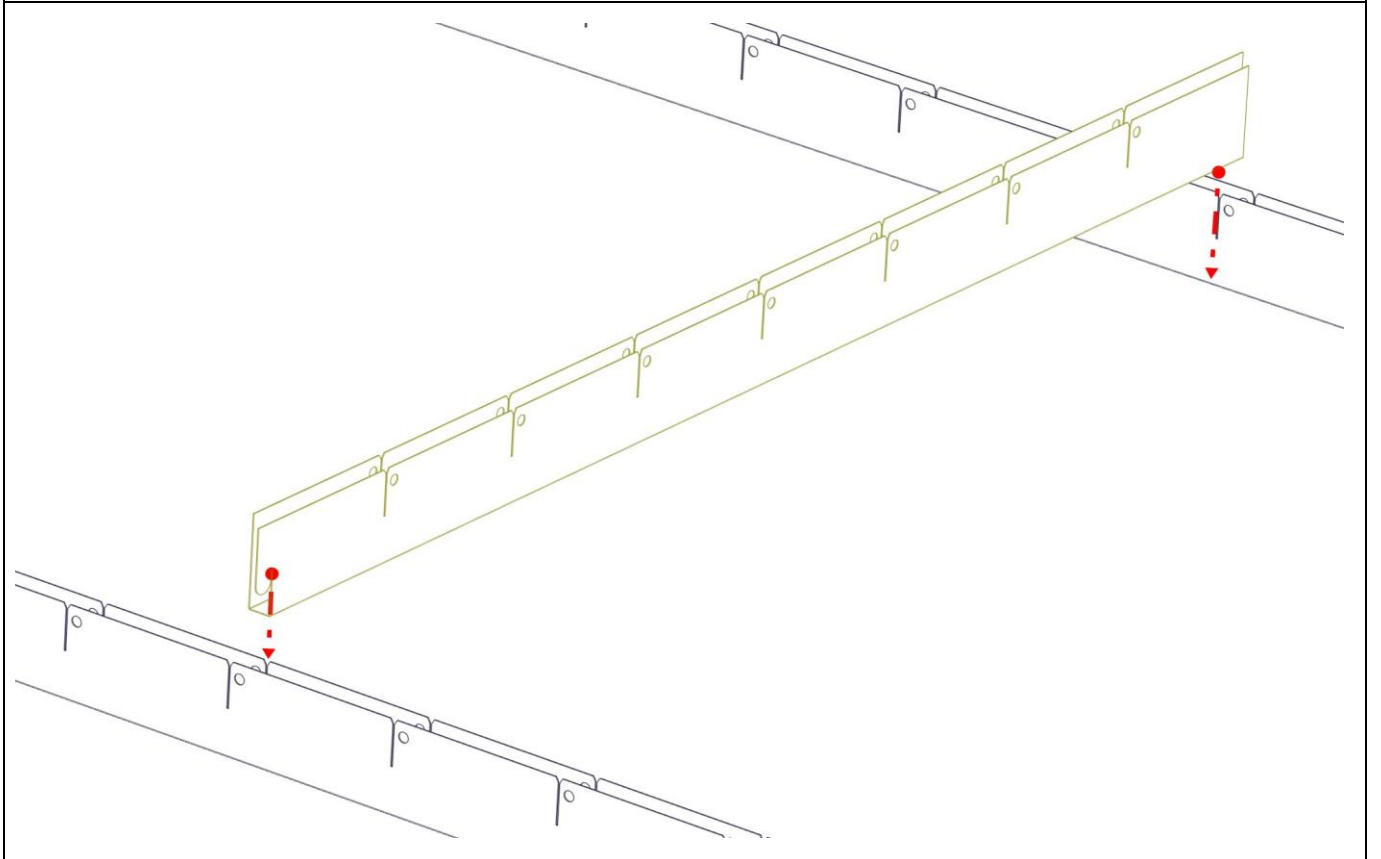
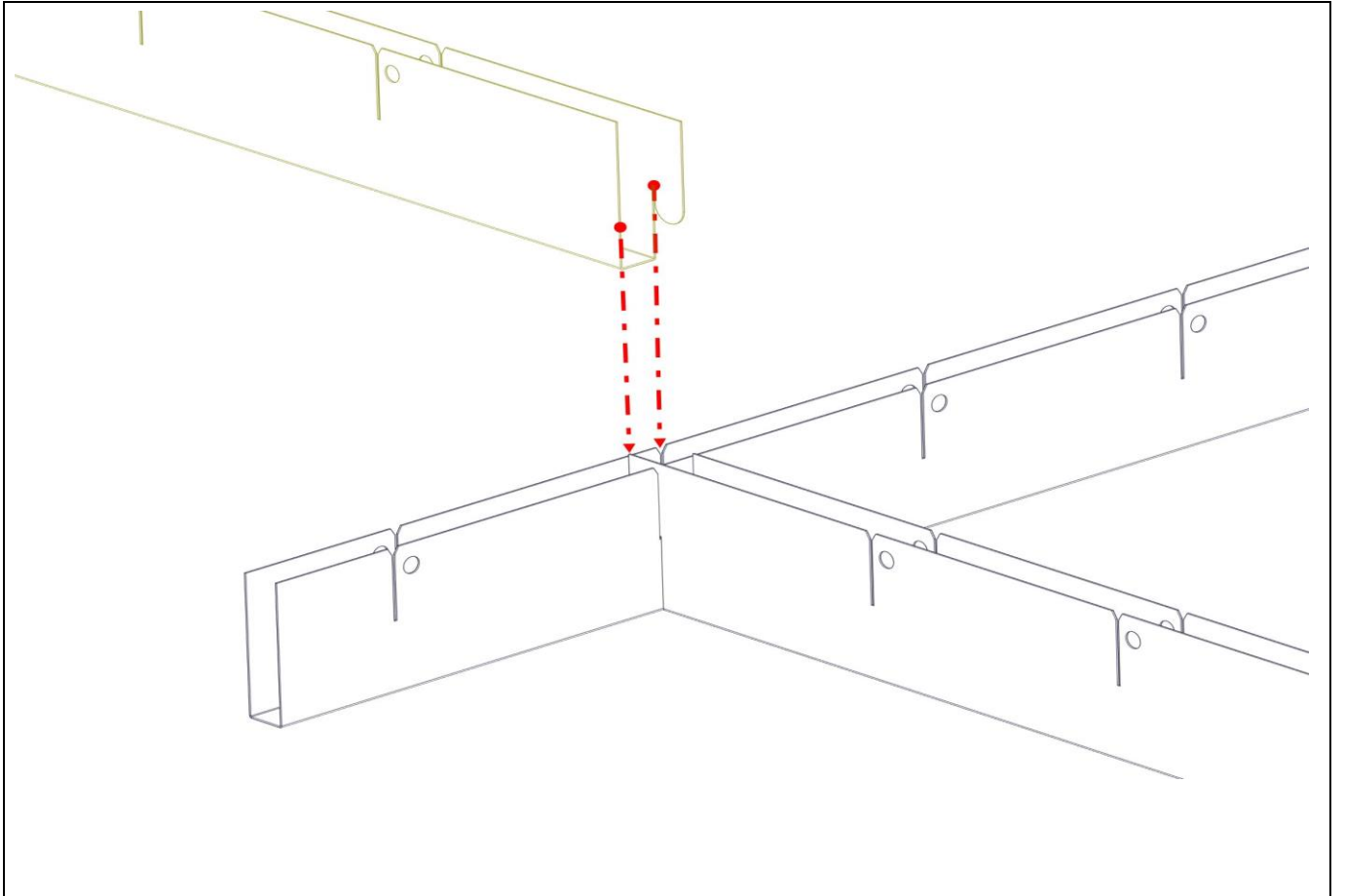

STEP 8.

## STEP 9.

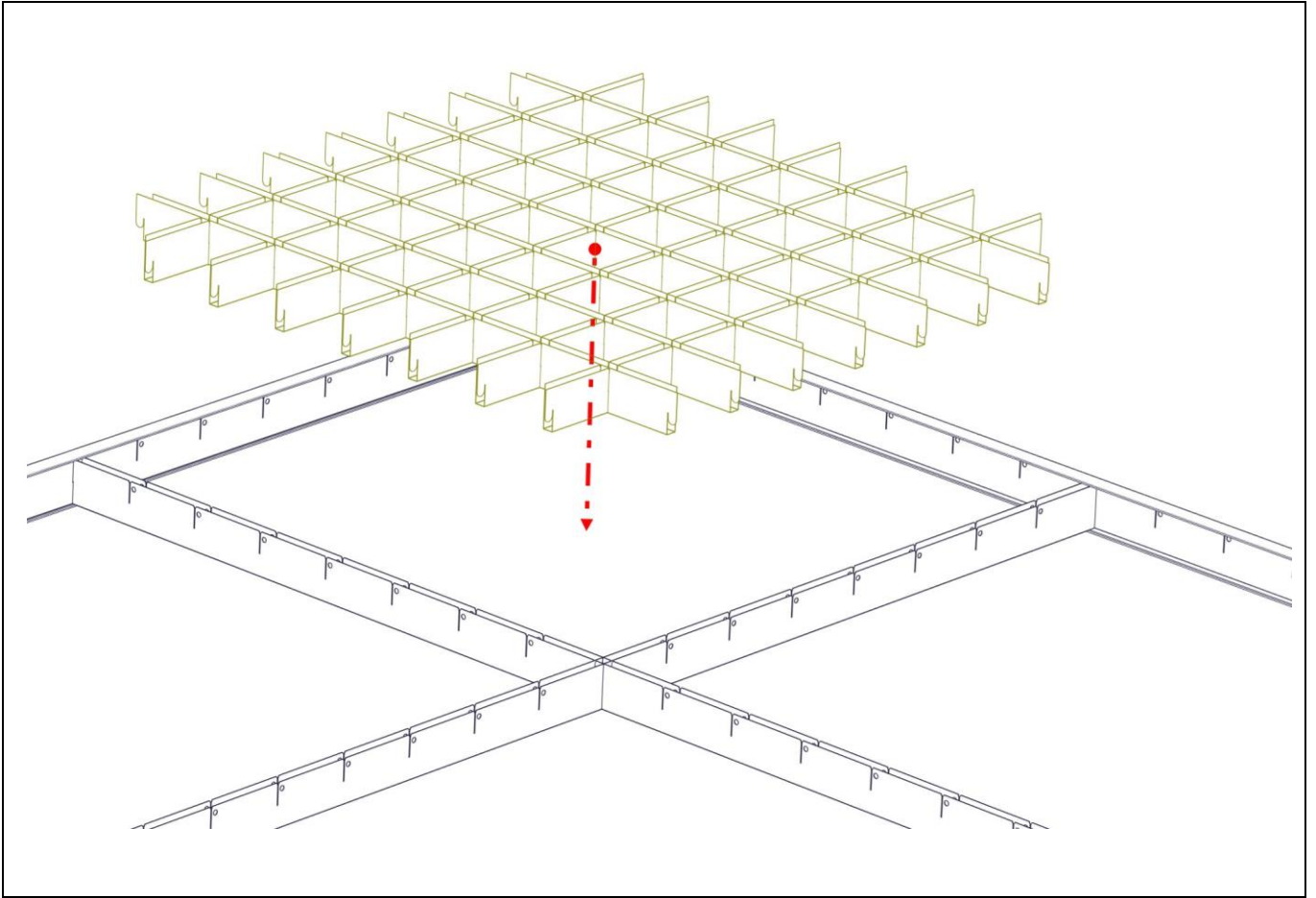

# Declaration of Performance

No:A-INT.PD20171001-01



1.Uniquade identification code of the product-type:	"BUTEM" Metal Ceiling Systems
2.Type, batch or serial number or any other element allowing identification of the construction product as required pursuant to Article 11 (4):	Product Type, Order/Batch Nr.
3.Intended use or uses of the construction product, in accordance with the applicable harmonized technical specification, as foreseen by the manufacturer:	Internally, to produce an installed suspended ceiling
4.Name, registered trade name or registered trade mark and contact address of the manufacturer as required pursuant to Article 11 (5):	<b>BÜTEM METAL FORM SANAYİ TİCARET A.Ş.</b> Osman Gazi Mahallesi Ziya Gökalp Caddesi No:10 Esenyurt Istanbul Turkey T:+90 (212)886 33 00 F:+90 (212) 886 33 10 www.butemmetal.com.tr
5.Where applicable, name and contact address of the authorized representative whose mandate covers the tasks specified in Article 12 (2):	Not Applicable
6.System or systems of assessment and verification of constancy of performance of the construction product as set out in Annex V:	Systems 3
7.In case of the declaration of performance concerning a construction product covered by a harmonized standard:	(a)The manufacturer carrying out factory production control; (b) Turkish Standards Institution (TSE) /Notified Body No:1783 issued the Reaction to Fire classification report (Report No:TSE-19.01.2017-170050) according to TS EN 13501-1+A1:2013-04 as the notified testing laboratory (based on sampling carried out by the manufacturer).
8.In case of the declaration of performance concerning a construction product for which a European Technical Assessment has been issued:	Not Applicable

# Declaration of Performance



No:A-INT.PD20171001-01

## 9.Declared Performance

- (a) Column 1 shall contain the list of essential characteristics as determined in the harmonized technical specifications for the intended use or uses indicated in point 3 above.
- (b) For each essential characteristic listed in column 1 and in compliance with the requirements of Article 6, Column 2 shall contain the declared performance, expressed by level or class, or in a description, related to the corresponding essential characteristics. The letters 'NPD' (No Performance Determined) shall be indicated where no performance is declared.
- (c) For each essential characteristic listed in column 1, column 3 shall contain:
- I-Dated reference of the corresponding harmonized standard and, where relevant, the reference number of the Specific or Appropriate Technical Documentation used; or
  - II-Dated reference of the corresponding European Assessment Document where available and reference number of the European Technical Assessment used.

Essential Characteristics	Performance	Harmonized Technical Specification
<b>Reaction To fire</b>	A2-s1, d0	TS EN 13964:2014-04 + TS EN13501-1+A1:2010
<b>Release of Dangerous Substances</b>	No Content	TS EN 13964:2014-04 + TS EN13501-1+A1:2010
<b>Flexural Tensile Strength</b>	NPD	TS EN 13964:2014-04 + TS EN13501-1+A1:2010
<b>Thermal Conductivity</b>	NPD	TS EN 13964:2014-04 + TS EN13501-1+A1:2010
<b>Durability</b>	Corrosion Class B	TS EN 13964:2014-04 + TS EN13501-1+A1:2010
<b>Sound Absorption Single Value <math>a_w</math></b>	See Table Below	TS EN 13964:2014-04 + TS EN13501-1+A1:2010

Sound Absorption Single Value $a_w$	Perforation Types		
	Ø1,5 mm	Ø1,8 mm	Ø2,5 mm
JM 60	-	0,35	0,35
Royalin R6/60	0,60		
JM 60 Double	0,45		
JM60 with 25 mm 50 kg/m <sup>3</sup> rockwool	1,00		

10.The performance of the product identified in point 1 and 2 is in conformity with he declared performance in point 9.

This declaration of performance is issued under the sole responsibility of the manufacturer identified in point 4.